

# Information Display

The Official Journal of the Society For Information Display

RECEIVED  
MAY 4 1976  
B. J. LECHNER  
SID  
INTERNATIONAL SYMPOSIUM  
MAY 4, 5, 6, 1976  
BEVERLY HILLS, CA.  
VOLUME 12, NUMBER 2



Allen B. DuMont: Early CRT

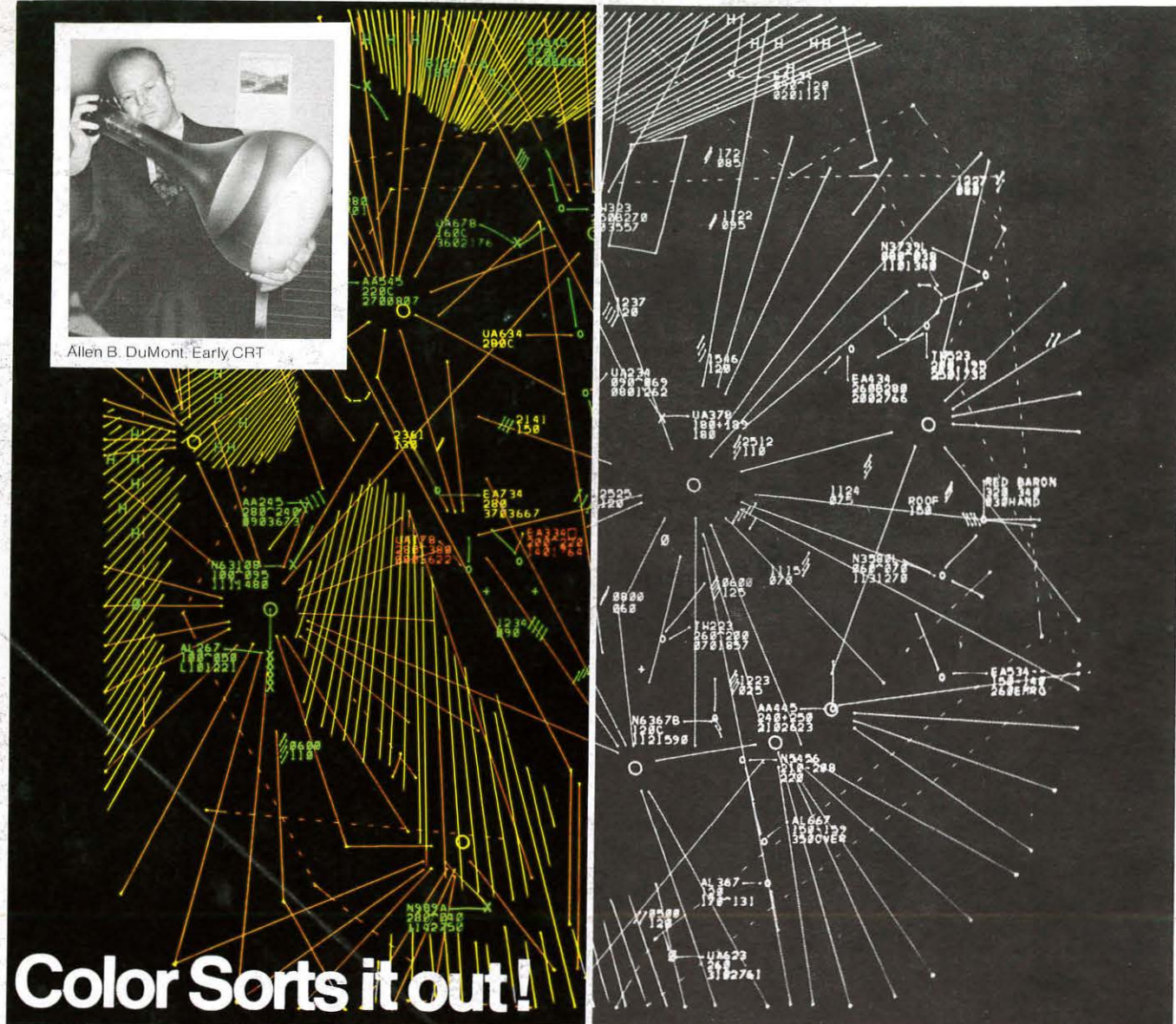

## Color Sorts it out!

Typical Air Traffic Control Presentation Courtesy CPS Inc.

For more than forty years, ever since DuMont introduced the commercially-produced cathode-ray tube (inset, above), professional users of high-resolution CRTs have worked with only a part of their natural visual capacity. They have been limited by single-color phosphor screens. Multi-color screens have been available, but only in low-resolution shadow mask and similar tubes.

**Now, with the introduction of DuMont's proprietary P49 color penetration phosphor screen, professional users can have a vivid, four-color display AND high resolution—resolution comparable to that of high quality monochrome CRTs—with superior contrast and clarity.**

COLOR sorts out complex data, emphasizes critical priority information, reduces operator fatigue. Operators assimilate color-classified data faster, make accurate judgments more quickly, reach decisions and take action sooner than when working with monochrome displays. Input data processors can readily be programmed to detect input errors or illicit codes and alert operators by a visual alarm signal!

We've shown an Air Traffic Control display, but it could just as well have been for:

- Public utility power dispatching
- Nuclear reactor status

- Municipal traffic control
- Military command and control
- Refinery/chemical process control
- Transportation control and dispatch

And most computer-controlled graphic display systems that now use monochrome CRTs can be converted to color with only minor hardware and programming changes.

Make *your* present—or next—display system more effective with DuMont's P49 high-resolution color CRTs. Call us for information about high-brightness color-penetration CRTs in sizes up to 25-inch diagonal—(201) 773-2000. Or write to:



Subsidiary of THOMSON-CSF

See Us at SID

No other company has as much CRT experience.

**DuMont** Electron Tubes & Devices Corporation  
750 Bloomfield Avenue □ Clifton, New Jersey 07015



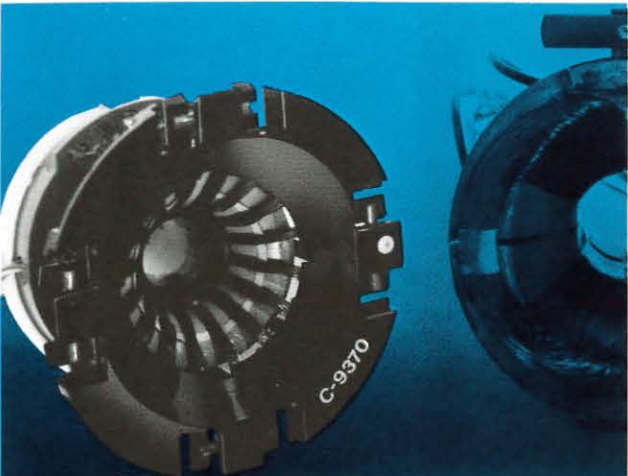

## How to be a hit with Sales

Give them a CRT display they can sell with pride. You can do it by simply specifying Syntronic's C-9370 stator-wound yoke. The C-9370 is a precision yoke with correction magnets built-in and preset to eliminate geometric distortion. On the production line C-9370's cut set-up time to a bare minimum. What's more, you eliminate the necessity for buying magnets and mountings. Everyone in Sales really appreciates a product with salability measured in ideal geometry and resolution. Besides, you'll be credited with lowering the rate of rejects caused by TV type yokes that fall short of standards your customers have set.

You know, a better display sells faster — the first time and all the time.

Complete Line for every Industrial & Military Display in Production Quantities or Custom Designed to your specific requirement.

See us at Booth number 390

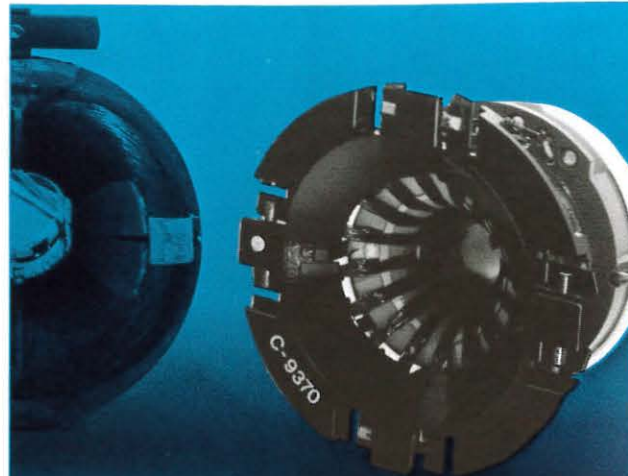

## How to impress Accounting

That's the department most likely to be impressed by "bottom line" results. And, why we've developed the C-9370, a stator-wound yoke. It does (we admit) cost more than the ordinary TV type saddle yoke, but results in the most favorable "bottom line" figure.

You can prove that to yourself. Finish filling in the column below:

	Ordinary TV type yoke	Syntronic C-9370 Yoke
Cost of yoke	\$ _____	about \$25 in quantity
Cost of correction magnets	\$ _____	(not necessary)
Cost of hardware to hold magnets	\$ _____	(not necessary)
Cost of labor to attach magnets	\$ _____	(not necessary)
Cost of labor to adjust magnets	\$ _____	(not necessary)
Cost of replacing rejected yokes that fall short of meeting customer standards	\$ _____	(not necessary)
Cost of recycling product that does not meet Q.A. standards due to yoke deficiencies	\$ _____	(not necessary)
Cost of field service to make adjustments to satisfy customer	\$ _____	(not necessary)
Extra sales expense and "persuasion" necessary to sell non-competitive displays	\$ _____	(not necessary)
"Bottom line" total	\$ _____	\$25

  
**syntronic instruments, inc.**  
 100 Industrial Road, Addison, IL 60101  
 Phone: (312) 543-6444

# Information Display

The Official Journal of the Society For Information Display

Volume 12, Number 2



**Publisher**  
Society for Information Display

**Publication Chairman**  
Thomas V. Curran

**Editor**  
Erwin Vodovoz

**Circulation**  
June Friend

**Advertising**  
Ron Thorstenson

### SID NATIONAL OFFICERS

**President**  
Robert C. Klein

**Vice-President**  
Erwin A. Ulbrich

**Secretary**  
B.J. Lechner

**Treasurer**  
Patricia A. Dupuis

### COVER:

Our cover photo is courtesy of I/O Metrics (article on page 6) and was taken by T. Wohlmut.

### THE OFFICIAL JOURNAL OF THE SOCIETY FOR INFORMATION DISPLAY.

Published bimonthly by the Society For Information Display, 654 North Sepulveda Boulevard, Los Angeles, CA 90049, Phone (213) 472-3550. Correspondence regarding editorial material, reprints, and subscriptions should be sent to the above address.

Correspondence regarding advertising should be sent to Western Media Sales, 23712 Bessemer Street, Woodland Hills, California 91364.

Copyright 1976 by The Society For Information Display  
Controlled circulation postage paid at Los Angeles, CA.

Published April 1976

### CONTENTS

- Systems Application of Film-Based Optical Video Discs . . . . . 6  
By Jonathan A. Jerome
- A Review of the MCA Disco-Vision System . . . . . 12  
By Kent D. Broadbent
- The RCA "SelectaVision" VideoDisc System . . . . . 20
- SID International Symposium . . . . . 25

### DEPARTMENTS

- President's Message . . . . . 4
- New Products . . . . . 27
- Advertiser's Index . . . . . 30
- Sustaining Members . . . . . 30

# PRESIDENT'S MESSAGE

It has been my privilege to serve as President of the Society for Information Display during the past two years. Discharging the responsibilities of this office, objectively, affords one a uniquely all-encompassing perspective of the SID. Based on this experience, I would like to share with you my assessment of the Society, its strengths and weaknesses, what has been achieved and what, I believe, remains to be accomplished.

We are a powerful technical group. Consider our size and examine our impact on the technology scene. SID has become a testing ground for new concepts and thoughts; the recognized forum for scientific debates. We have succeeded in attracting to our ranks the finest minds in the display field. This self-perpetuating process continues to snowball. But more should be done, particularly in the area of display standards — nationally and internationally.

Over the years, the SID Proceedings have achieved such stature that few articles dealing with display technology fail to list one or more Proceedings issues in their bibliographies. Library subscriptions continue to grow. An excellent job is being done in this area.

Our technologically outstanding Symposia continue to be plagued by mundane administrative problems. Ways must be found to speed up distribution of advance programs. Deteriorating mail service and continuing competition for the time and dollars of prospective attendees demand improvement in this area.

A long term viable publications arrangement must be established for Information Display. This subject has been explored so extensively that it would be redundant to elaborate further. Suffice to say that good progress is being made toward this goal.

Inadequate communications between the Society's administration, SID's Chapters and individual members remains a nagging weakness. The "President's Message" in Information Display is really not suitable for this purpose. It is too short, infrequently published, too broadly circulated and restrictive by virtue to the medium. To overcome this, letters dealing with major issues have recently been circulated to all Board Members, Chapter Chairmen and National Committee Chairmen. Individual members remain dependent on Chapter meetings and local newsletters for dissemination of such information. They should be encouraged to express their views to the National Office.

Administratively, strong policies have been implemented to assure competitive procurement for all major disbursements. Financial responsibility and authority to the Chapter level have been clarified through bylaws changes.

Most important of all, SID Chapters are vigorous and creative. It is gratifying to see programs from the new chapters in Chicago and Japan rivaling and occasionally surpassing those of their well established counterparts in other areas.

I leave the Presidency, certain of SID's abiding technical predominance and confident that the extant administrative mechanisms will sustain sound management of the Society in the future.

My thanks to all of you who have and continue to give so much of your time, thought and effort in support of these objectives.

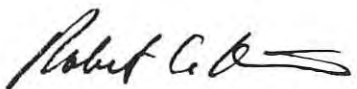

ROBERT C. KLEIN  
President — SID

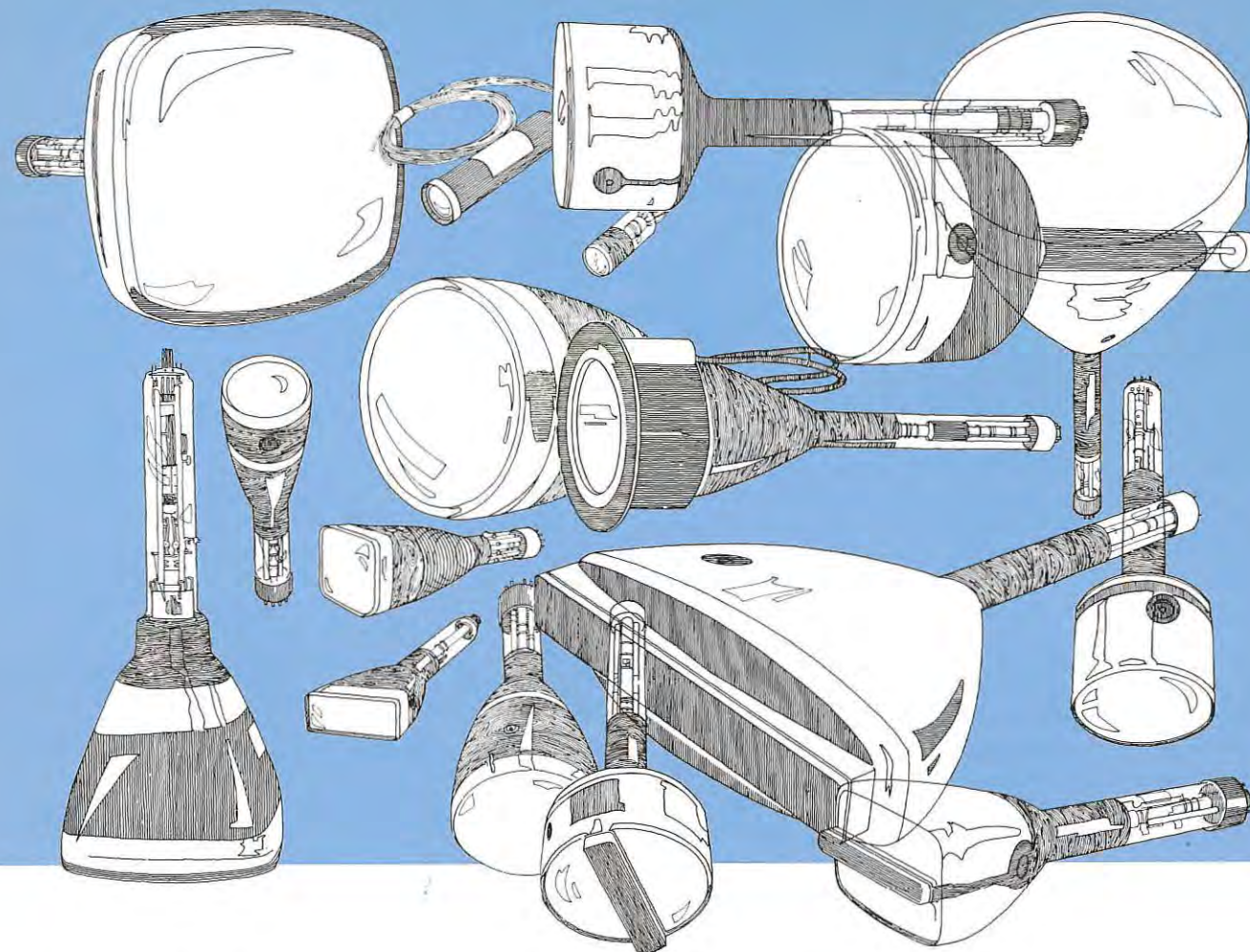

## Call on us for all commercial, industrial and military applications.

**A FEW APPLICATIONS INCLUDE:** Computer Display Consoles, Character Readers & Film Scanners, Desk Top Calculators, Head-up—Radar & other Avionics Displays for Severe Environments, Reservation Counter Terminals, High Resolution Photorecording & Photo-composition Systems, Medical Electronics Monitors, Projection & Simulation Systems, Oscilloscopes & Studio Equipment, Air Traffic Control and Ground Support Displays.

*OUR NEW SHORT FORM CATALOG IS AVAILABLE UPON REQUEST*

# THOMAS ELECTRONICS, INC.

100 RIVERVIEW DRIVE, WAYNE, N. J. 07470 / Telephone: 201 - 696-5200 / TWX: 710-988-5836 / Cable: TOMTRONICS

# systems application of film-based optical video discs

Jonathan A. Jerome  
I/O Metric Corporation

Initial research and development of video discs have been directed to one limited goal: the retrieval of ten to thirty minutes of video and video-synchronized audio from one disc of approximately thirty centimeters diameter. The video and audio signals are to be compatible for playback on any typical, non-professional consumer television set, via transmission to the external antenna input of the set. Numerous systems to accomplish this goal have now been demonstrated. Attention is now centered on the further refinement of the demonstrated systems, and on the extension of the video disc capability to new areas of application. A summary of several of these potential areas of application is presented in Table I, along with an indication of the required disc formats and the disc player configurations. Also described in Table I is the consumer-compatible application, and some of the desirable features which could be added to the basic playback device.

APPLICATION	DISC PARAMETERS	PLAYBACK DEVICE CONFIGURATION
1. Video Playback	10-30 min. playing time from continuous video signal on spiral track	Realtime forward/reverse, stop frame, optional slow crawl/rapid advance
2. Video Visual Image Store	5,000-50,000 indexed circular video tracks	Computer controlled rapid-random access
3. Educational/Institutional	Segmented video signal on spiral track	Programmed interactive playback under local computer control
4. Read Only Memory/High Density Data Store	Circular video or circular computer compatible digital tracks	Fixed head, electronically switched video/digital read

Table I Applications and parameters/playback configuration for video disc systems.

Simple continuous retrieval of the video and audio information from a spiral track or a set of circular tracks can be accomplished by means of several different technologies, utilizing either magnetic, capacitive, mechanical, or optical means. However, whenever additional system requirements are introduced, such as extended stop-frame or rapid random access, only optical retrieval offers a significant capability. Indeed, even the simple system requirement of maintaining file integrity in use will in most applications eliminate all but an optical retrieval. Typical capacitive and mechanical retrieval means are limited to approximately 100 passes at the data on the disc, at which point significant degradation is introduced. Magnetic storage of the information on the disc does not provide archival protection in the presence of small thermal and magnetic shocks.

A final consideration with respect to systems applications of optical-based video discs is the overall ease with which the video disc component of the system may be used. A film-based video disc technology offers maximum flexibility in those areas where only small numbers of copies are made, and where mastering and duplicating costs would otherwise dominate. A non-film based optical technology requires a complex sequence of steps to generate a playable copy. For example, to generate a pressed PVC disc for use with an optical readout, the following steps are required: first, a metal coated glass master is mounted. The video signal is burned into the metal coating using a high power laser. The metal coating is subsequently over-coated with a layer of photoresist that is exposed through the under-surface of the disc to ultra-violet light. A negative working photoresist is used, so subsequent development leaves only the exposed areas. Finally, electrodeposition of an appropriate metal on the photoresist yields a stamping tool which may be used to press PVC discs. In contrast, a photographic film disc is exposed with a low power laser, and developed in under ten minutes in a simple automated film processor. Here, the master photographic film disc is immediately playable, or may be used to generate copies by means of a simple contact printing process.

In order to exploit these basic advantages of the film-based video disc technology, development of the recording and playback capability, as described below, has been in the direction of greatest ease and most natural execution.

## FILM DISC RECORDING

The actual recording process for a given video film disc depends on the eventual application in which the disc will be

used. A general recorder has been developed which is consistent with recording file-indexed circular tracks or a continuous spiral at arbitrary densities exceeding 500 tracks/mm. The optical layout of the recorder is presented in Fig. 1. In detail, a low power 3mw HeNe laser delivers light to an acousto-optical modulator. The signal of interest is induced on the laser beam by means of the modulator driver. This signal can be either the direct analog video signal, or a frequency or pulse position modulated video signal, or in general any analog or digital signal. The modulated laser beam is delivered to the surface of the film disc by an ordinary microscope objective, with a numerical aperture chosen between 0.1 and 0.8, depending on the particular application. Further details include a beam contractor before the modulator to increase its frequency response to -3dB at 7MHz; and a set of transfer optics to match the aperture of the modulated beam to that of the microscope objective.

## Laser Disc Recorder

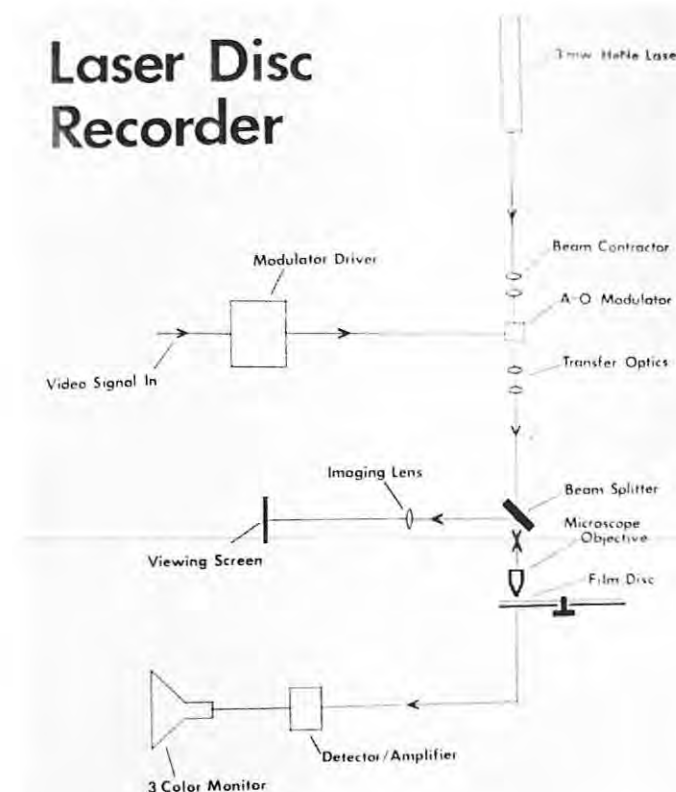

Figure 1. Optical/mechanical layout of the laser disc recorder for recording the floppy disc mode.

All recording is carried out directly on the film sheet in a floppy disc mode without using any rotating supporting substrate. Historically, film-based disc recording was carried out using emulsions bonded directly onto glass plates, or film sheets mounted on large optical flats. This use of massive glass substrates introduces considerable mechanical difficulty and also considerable danger, as the discs must be rotated in excess of ten times per second. Elimination of the glass substrate by recording directly on the film sheet supported only by an air bearing significantly simplifies the mechanical configuration and also makes the practicing of the recording process significantly easier.

The most severe mechanical constraint remaining is that the disc must spin flat to the depth of focus of the recording objective, or several microns. The film disc is a 100 $\mu$  thick mylar sheet with an emulsion on the order to 5 $\mu$  thick; it is spun some hundreds of microns above an appropriately

configured stationary support plate. The rate of rotation required by video and high bandpass digital recording, in excess of 10Hz, is sufficient to flatten the disc at any one fixed radius to several microns. The film sheet is of course a flexible membrane, and hence acquires a radial profile in rotation. By appropriate choice of the support plate, the air bearing will generate a profile flat to within 10 $\mu$  over the disc radii at which recording is carried out. Fig. 2 shows a typical disc profile as measured on the recorder. Note that the most rapid variation of vertical position of the disc surface occurs at the larger radii, where the signal recorded is least affected by such variations. Fortunately, a given disc profile does not seem highly sensitive to local irregularities (on the order of 50 $\mu$ ) of the stationary support plate. Instead, only the global character of the plate and the air flow that it introduces are important.

Control of the initial focus of the laser beam, and elimination of the effect of disc profile, are provided by directly viewing the focused beam on the disc surface. This is accomplished by introducing a beam splitter (actually, a clear optical glass) above the microscope objective. Light scattered from the emulsion back through the objective is re-imaged onto a viewing screen. Control of the focused beam by mechanical translation of the objective is to nearly a micron. Direction of motion (up or down) is indicated by using a slightly off-axis beam in recording.

As indicated in Fig. 1, the laser beam after passing through the film is directed onto a silicon photodiode. For maximum flexibility this can be done with a small fiber optic, thus allowing a realtime monitoring of the modulated laser beam throughout the recording process.

The resulting master disc is shown in Fig. 3. This particular disc has a 33cm diameter; the disc itself has the physical properties of an ordinary sheet of negative black and white photographic film. It contains a continuous spiral video track with a 2.7 $\mu$  center-to-center track spacing. The resulting playing time at the normal NTSC video framing rate is 20 minutes. Increases of playing time by a factor of two or three can be achieved by the layering of discs in the vertical direction. Playing time can also be increased by increasing the track density, or by the introduction of appropriate skip line or skip frame technique. In general, any of these means for significantly increasing the playing time requires additional sophistica-

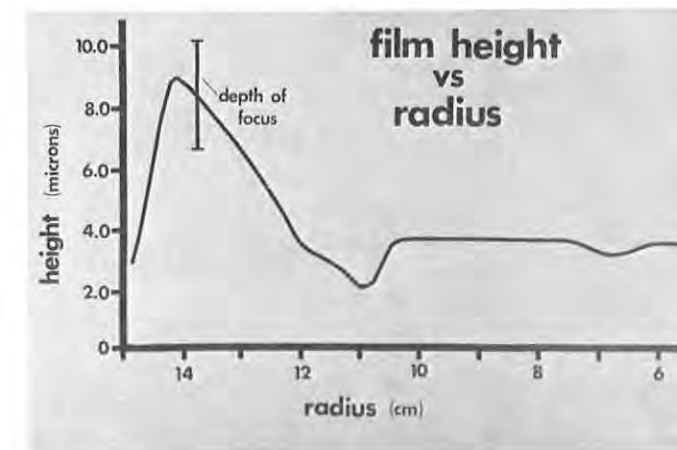

Figure 2. Variation in height of the film disc surface as a function of radius. Measurements were taken with the disc rotating at 1800 rpm, with the height at each radial point being an average for the disc circumference.

tion in the playback device.

The film-based video disc as shown in Fig. 3 is impervious to normal handling hazards. It can be stored or shipped in a rolled or flat form. The information contained on the disc itself has all of the usual archival characteristics associated with photographic film recording. Minor environmentally induced imperfections (fingerprints, dust, scratches) are out of focus or are undetectable when high numerical apertures are used on replay. Major environmental insults are often tolerable due to the inherent redundancy in a typical video signal. In general, restoration of the disc even after extensive handling is easily achieved by use of ordinary film cleaner to eliminate foreign matter accumulated on the disc surfaces.

#### FILM DISC PLAYBACK

Replay of the film video disc can be accomplished by use of either a laser or an incandescent light source. Use of the laser provides a higher bandpass and increased signal to noise ratio, at the expense of the requirement for more sophisticated optical and electronic servo systems. Also, the introduction of the laser playback operated at its higher bandpass introduces coherent noise at the detector resulting from residual random film structure. However, careful optical alignment can produce a high quality video signal compatible with a standard television display. This is indicated in Fig. 4 (photo on front cover). Here the laser recorder is being used to replay a previously exposed and developed film disc. The original signal recorded on the disc was a full NTSC signal, derived from a normal commercial video broadcast ("Rhyme and Reason," W.T. Naud Productions). Visible in the foreground is the laser beam which is here being used to read the signal on the disc. The signal was recorded in the direct analog mode with pre-emphasis at the 3.58MHz sub-carrier frequency. The signal as presented on the standard 3-color monitor is derived directly from the amplitude modulation of the laser intensity by the analog pattern on the disc; the only signal processing involved in retrieval is the restoration of the chrominance time-base stability, to allow use of a non-critical, free-running rotation of the disc.

Many systems applications require a less critical configuration involving an incandescent light source rather than the coherent laser source. Fig. 5 shows a standard opto-mechanical design appropriate for use with an incandescent source. Playback device development has been directed towards maximum ease and maximum stability in use for such applications. Basic to this capability is the inherent flexibility of the non-contact optical read method, the utilization of an incandescent source for illumination, and the careful exploitation of the advantages of flying the disc in the floppy disc mode. Fig. 6 shows successful retrieval of video data from a video player which is being casually hand-held. Even the extreme environmental conditions depicted (non-stable mounting at an extreme angle) do not significantly alter retrieval quality. Operation of the video player is considerably more reliable than operation of an ordinary audio turntable.

An important system application indicated in Table I is the storage of file related data. This data can be text or pictorial in nature, or a combination of both. For example, an identification system based on a standard driver's license would be compatible with a simple monochrome data retrieval. Fig. 7 shows the retrieval of a single fixed video frame from a film disc. Here an incandescent source was used with detection effected by a silicon photodiode. The photodiode was operated with a proprietary non-nominal current sensing circuit to maximize the perceived signal to noise ratio.

This type of file material can easily be indexed, with each

frame on one disc or on a sequence of discs being tagged with a unique number in one of its vertical retrace intervals. (In Fig. 3, the vertical retrace intervals are visible as the wide radial bands some 10° in extent. These bands provide the vertical synchronization for the video signal. An embedded



Figure 3. Appearance of the video film disc. This particular disc has a playing time in excess of 20 minutes at the full NTSC video framing rate.

indexing code in this interval would not appear on a standard television display.) Retrieval can be automated and carried out under either local or remote computer control. Under local control, a file number manually loaded into the external read register of a computer residing within the video player would initiate retrieval of the desired video frame. For more extensive systems, for example in the maintenance of financial or accounting file data, one video player may be interfaced to a large number of separate read terminals. One master com-

#### VIDEO DISC PLAYBACK UNIT

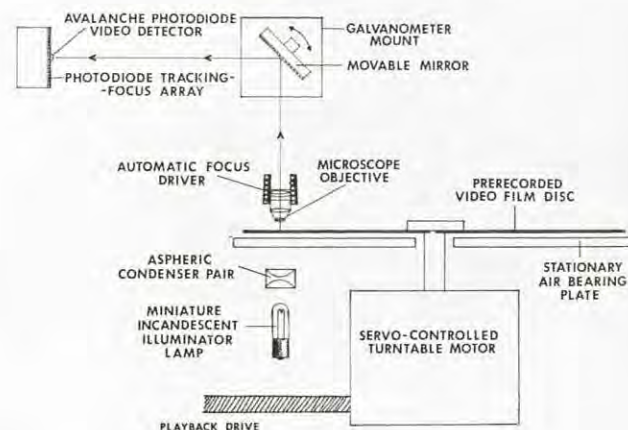

Figure 5. Optical/mechanical layout of the standard playback device which uses an incandescent source.

# RCA leads the way to better display.

How? With the industry's broadest line of display devices — AND with full product information that's yours . . . FREE . . . for the asking.

Today, there are ten families of RCA Display Devices, ranging from direct view and projection kinescopes to photorecording and flying spot scanner CRTs. RCA also offers complete custom-device service, designed to accommodate your specialized requirements.

Outstanding examples of the RCA line are projection kinescopes. There are 30 different types, for applications from theater TV to data presentation. Handling power from 3¼ W to 160 W, they are available in bulb diameters from 3 to 7 inches, and in maximum operating voltages of 35 to 80 kV.

Need high resolution photorecording CRTs? RCA's standard and customized coverage is unequalled. Choose from 5- and 7-inch diameter types with either electrostatic or magnetic focusing in a variety of line widths. Each comes in your choice of exclusive RCA-produced phosphors.

RCA's flying spot scanner CRTs for video signal generators now include types for full color and monochrome TV. For more information on these RCA Display Devices — and your FREE copy of the brochures pictured — see your RCA Representative or complete and return the coupon.



Manager Marketing Planning  
RCA Display Devices  
New Holland Ave.  
Lancaster, Pa. 17604

Please send more information on:

- \_\_\_\_\_ Full line RCA Display Tubes (STC-900D)
- \_\_\_\_\_ RCA Projection Kinescopes (STC-902A)
- \_\_\_\_\_ RCA Photorecording CRTs (STC-905)
- \_\_\_\_\_ RCA Flying Spot Scanner CRTs (STC-905)
- \_\_\_\_\_ Have a salesman call.

Telephone \_\_\_\_\_  
Section 199L

----- This is your mailing label. Please print. -----

Company \_\_\_\_\_  
Street \_\_\_\_\_  
City \_\_\_\_\_  
State \_\_\_\_\_  
Zip \_\_\_\_\_



# RCA Display Devices

INTERNATIONAL SALES OFFICES: ARGENTINA — Casilla de Correo 4400 Buenos Aires/BRAZIL — Caixa Postal 30433, São Paulo/CANADA — 21001 No. Service Rd., Ste. Anne de Bellevue, 810 Quebec/ENGLAND — Sunbury-on-Thames, Middlesex/HONG KONG — P.O. Box 112/MEXICO — Apartado 17-570, Mexico 17, D.F./SWITZERLAND — 118 rue du Rhone CH1204, Geneva

puter may then control access to the video file by establishing the appropriate queing; system access time is minimized by buffering the file with a frame-grabbing capability. In this mode, the maximum access time to any frame on a disc from any one read station should be no more than one second.

In considering file data applications, the characteristics of a film stored data base must be recognized. That is, a file



Figure 6. The video signal displayed is generated directly by the hand-held video player, demonstrating operation under environmental stress.



Figure 7. The video frame presented on the monitor is derived from a video player using a film disc and an incandescent source for illumination.

which is continuously revised would more naturally be maintained as a magnetic stored data base. However, for those files for which file integrity is critical (such as financial files), or for those files for which only additions and not revisions are needed (generally called library files), a film-stored data base is a clear advantage.

Of the further systems applications listed in Table I, the use of the video disc medium as an instructional device is almost immediately obvious. This use can be carried out at several levels of sophistication. At the most primitive level, the video disc and player can be used as a simple training device. Physical actions and verbal instructions can be demonstrated and repeated in great detail either continuously or over and over, at the requirements of the viewer. The software material can be segmented into a programmed sequence, with progression through the sequence under viewer control. At the most advanced level of use of the disc medium, progression through the software would be under local computer control. The progression would be determined by interaction between the viewer and the computer: questions would be generated from the software material on the disc, and presented to the viewer at appropriate branch points. The viewer's responses would be weighed by the computer, and would be used to calculate subsequent program progression. Here it is important to note that many of these instructional applications would involve only very limited numbers of copies of discs on a given subject. It is in this situation that the ease of mastering and replication becomes the paramount consideration.

The final systems application in Table I is the use of the film based video disc as a read-only memory. In this area, the data storage capacity and the rate and the accuracy of the data retrieval are of primary importance. A typical full frame NTSC color video signal is equivalent to in excess of  $10^7$  bits per second; thus the video disc is capable of delivering data at a rate in excess of 10 megabit/sec. However the data accuracy is compatible with the normal highly redundant video display, and is of a lower quality than that generally required in many read-only memory applications. Increasing the accuracy to a level compatible with typical computer memory requirements entails considerable data redundancy in the form of error detection and correction codes. Also the requirements of data addressing on the disc form a significant overhead on the data storage capacity. As a result of these considerations, optical disc systems demonstrated to date show considerably less capability than the  $10^{12}$  bits/m<sup>2</sup> ( $10^{11}$  bits/disc) calculable attainable maximum with an optical read system.

Of course, if the contents of the read-only memory are data in the form of video images, the usual advantages of the optical video disc are available. A data store used in a refresh video display would be a natural application of the video disc; this type of system has been developed and is worthy of discussion in some detail. In the typical refresh application, the ability to switch rapidly from one video image to another is a considerable advantage. It is difficult to do this using a laser read-out from the disc. The laser beam must be pointed to a micron-sized spot and mechanically steered from one track to another by moving a mirror. This requirement of a physical motion introduces definite limitations on the switching rate and the maximum distance between tracks which may be covered during the switching time. Introduction of multiple laser readheads, each head with its own steering optics, is hardly practicable. In contrast, the use of an incandescent source for illumination, and the imaging of the disc surface back up to the detector(s) allows immediate access to all data tracks within the optical field of view. Further, with detection of one data track effected by a photodiode, an array of photo-

diodes provides a means of switching in a very short period of time ( $< 200$ ns) between arbitrarily chosen tracks. There are no mechanical limitations on switching times, and configurations in which there is one readhead (that is, one photodiode) per track may easily be constructed.



Figure 8. The video frame presented on the monitor is constructed from four different data tracks on the disc. There is one read-head (photodiode) per track, with an electronic switch between tracks effected twice per line and twice per field.

One variant of this type of system results from the extremely short switching time available: the switching rate can be increased to exceed the 16kHz horizontal line rate by two orders of magnitude. As a result, one video field can be constructed from a number of distinct data tracks. Fig. 8 shows a replay in which each video field is constructed from an appropriately switched set of four photodiodes detecting four distinct data tracks. Each of the original data tracks generates a video image which consists of a set of four identical symbols (spades, hearts, clubs or diamonds) appearing in the four quadrants. The video image that results from the switching among the four data tracks shows a different symbol in each quadrant. The switching is carried out twice per line and twice per field; permuting the switching order permutes the symbols' positions. The switching is clocked by a fifth photodiode observing a timing track on the disc which is adjacent to the data tracks.

Manipulation of the video signal by track switching in this fashion is possible only with a light source imaging the data

tracks onto a solid state detector array. Also, this type of track switching offers the prospect of completely eliminating the requirement of mechanically following video tracks in the other systems applications described above. The switching rates required for solid state tracking are quite low ( $< 5$ kHz) and the switch can take place in the horizontal retrace interval. Solid state tracking as used on an imaging optical system eliminates a major mechanical servo system and considerably improves the reliability of the video image retrieval.

#### ACKNOWLEDGEMENT

I wish to thank Noel Quigg for his assistance in recording the video discs used in illustrating this paper.

#### about the author



Jonathan A. Jerome is a Research Scientist with i/o Metrics Corporation, with primary responsibilities in the area of assessing and implementing the storage and retrieval of information from photographic film. He also serves as Vice-President for Videonics of Hawaii, Inc., conducting development of the film-based video disc system.

His academic background includes a Master's Degree in Physics from the University of Hawaii, with graduate work in the area of graphical data bases and their conversion to computer data bases.

Work experience prior to joining i/o Metrics/Videonics includes two years with Avco-Everett Research Laboratory evaluating and applying high resolution, astronomical video imaging and video tape storage systems.

# A Review of the MCA Disco-Vision system

Kent D. Broadbent  
MCA Disco-Vision System

The MCA Disco-Vision system can be considered in terms of three techniques:

1. Mastering
2. Replication
3. Playback

## 1. MASTERING

The recording medium is a thin metal film evaporated onto an optically polished plate glass disc 0.24" thick. Glass was chosen because it is very uniform and because its surface can be made smooth and free of scratches, pits and other blemishes by the well-known techniques of optical polishing. Starting with discs cut from twin-ground plate glass the surface may have hundreds of small pits per square millimeter. These discs are then reground with a fine abrasive to get rid of the deepest pits. Finally, the surface is optically polished until the pit density is reduced to less than 10 per square millimeter. The disc is then cleaned chemically and transferred to a vacuum evaporator where it receives a metallic coating a few hundred angstroms thick. For recording the disc is transferred to the mastering machine where a laser beam records picture and sound information by selectively melting the metallic coating.

The layout of a twenty-minute disc is shown in Fig. 1. The information track is a spiral of 2 micrometers pitch which is read from the outside in.

One TV frame is recorded per revolution of the disc. The information is recorded as a series of holes cut in the thin metal film deposited on the glass disc. The holes range in size from circles 1 micrometer in diameter at the 3" radius to ovals 1 micrometer x 2 micrometers long along the path at the outer radius. The recording has a mean wavelength of 3 micrometers.

Various techniques are available to lengthen the twenty-minute playing time of the described configuration. A forty-minute Disco-Vision record has been publicly demonstrated.

To minimize the cost of the processing electronics in the home player, the information on the disc is kept in the NTSC format required by the home TV set. The relative positions and frequencies of the video, chroma and sound subcarrier are preserved when going from the program signals to the signal represented by the holes in the disc coating; therefore, no

re-formatting or re-arrangement of signal components are required in the player and minimization of the player cost is accomplished.

The choice was made to record with frequency modulation (FM) because of its immunity to noise at low frequencies where much of the system noise is. The usual source of audio and video signals is a 2" video tape recorder. The audio signal is used to frequency modulate a 4.5 MHz carrier. This carrier

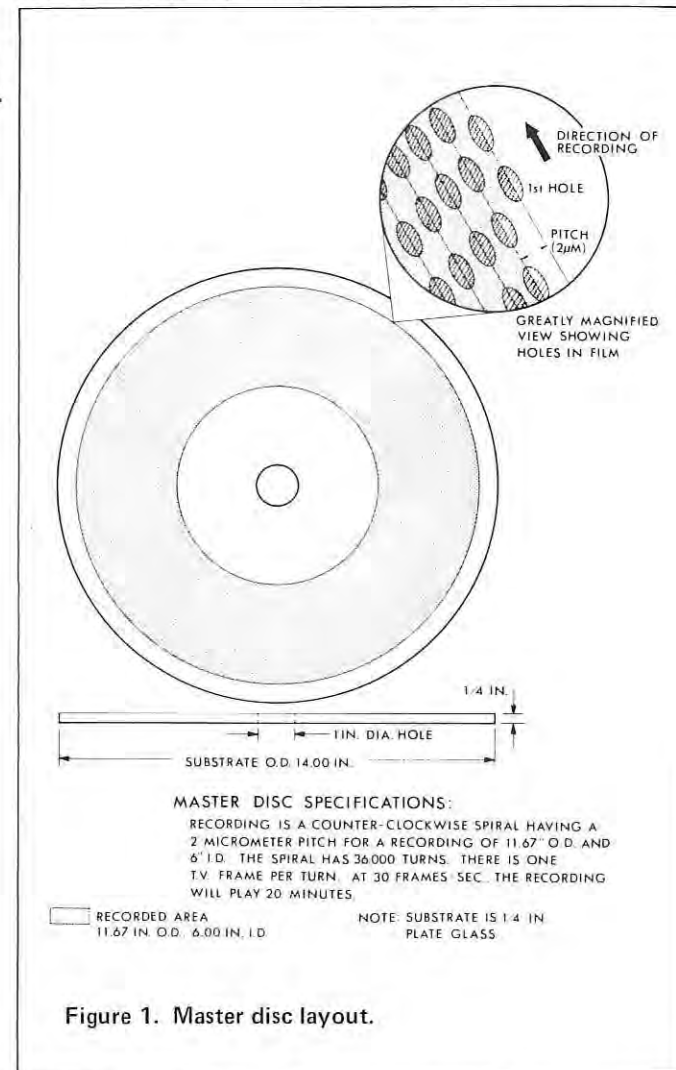

Figure 1. Master disc layout.

and the processed video are summed and fed to a voltage controlled oscillator (VCO). This device has a center frequency of approximately 7 MHz and a deviation of  $\pm 1$  MHz for a 1 volt peak-to-peak video signal. The recording polarity is such that sync tips produce the highest frequency, 8 MHz, and saturated whites produce the lowest frequency, 6 MHz.

Fig. 2 shows the basic signal processing used in mastering and playback. In mastering, the resulting FM signal occupying a spectrum from approximately 2.5 to 11.5 MHz, is applied by the cell driver to a Pockels cell electro-optical modulator. The Pockels cell has incident upon it the beam from the record laser. Under the influence of the signal from the cell driver, the Pockels cell alternately passes and blocks the beam, thus allowing the beam to produce holes and lands in the disc coating. An adjustable dc bias is applied to the Pockels cell to minimize 2nd-harmonic distortion that can be generated in the cutting process.

## Optical and Mechanical Techniques

Details of the physical arrangement required for cutting a master are shown in Fig. 3. An argon-ion laser produces the

basic "write" beam, which is modulated by the Pockels cell. Optics direct the beam onto the disc to produce the holes previously described. The rotatable Glan prism is used to adjust the average intensity of the beam reaching the disc. As shown in Fig. 3, the last few optical elements in the write beam are mounted on a carriage that is moved along the disc's radius by a motor-driven lead-screw. The objective lens is supported on an air bearing, which is loaded against the surface of the disc. A relatively small air flow at moderately high pressure maintains the head and objective lens at a constant distance of approximately 0.0005 inch (0.5 mil) from the surface of the disc. Fine focus adjustment is made by moving the diverging lens on the V block until optimum cutting is obtained.

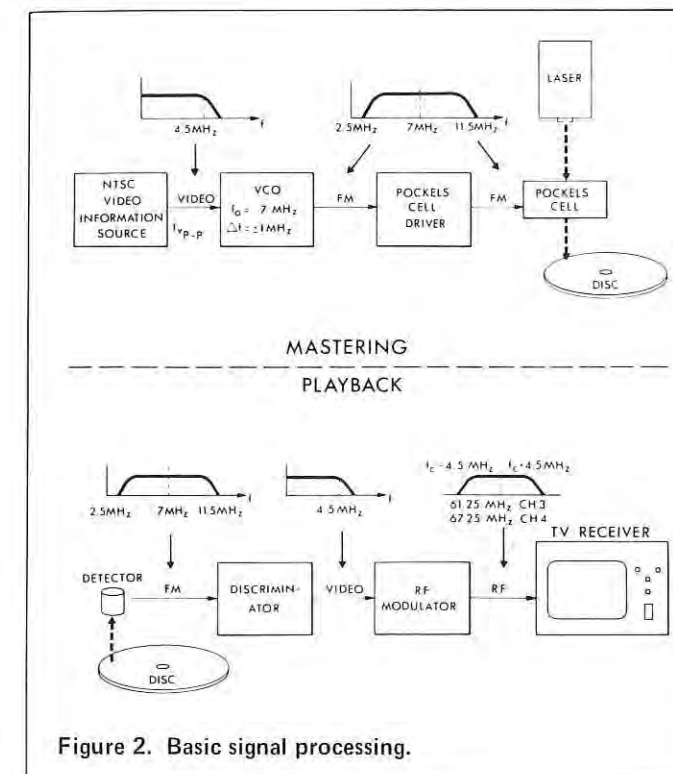

Figure 2. Basic signal processing.

## Read-While-Write

Since there is no need to develop or process the master in order to read it, an optical system is included in the mastering configuration so that masters can be read while they are being cut. This feature allows the recording parameters to be adjusted while cutting and also provides continuous monitoring of the video quality of the master. Measurements of SNR and other video parameters can be completed and logged while mastering is in progress. Continuous monitoring also reveals defects in the master which could only be detected by playing it.

The optical arrangement consists of a 1 milliwatt He-Ne laser, a beam splitter, a second diverging lens, an adjustable mirror and an adjustable dichroic mirror for combining the read and write beams before they enter the microscope objective. The two adjustable mirrors are used to position the read spot about 10 micrometers down stream from the write spot and directly on the track it has just cut. The 10 micron spacing insures that the recorded surface is in its final state at the time it is read. The return beam comes out the same way it enters (the system is retro-reflective) until a portion of it is reflected into a PIN photodiode by the beam splitter. The diode, pre-amp and discriminator are all components of the playback system described later in this paper.

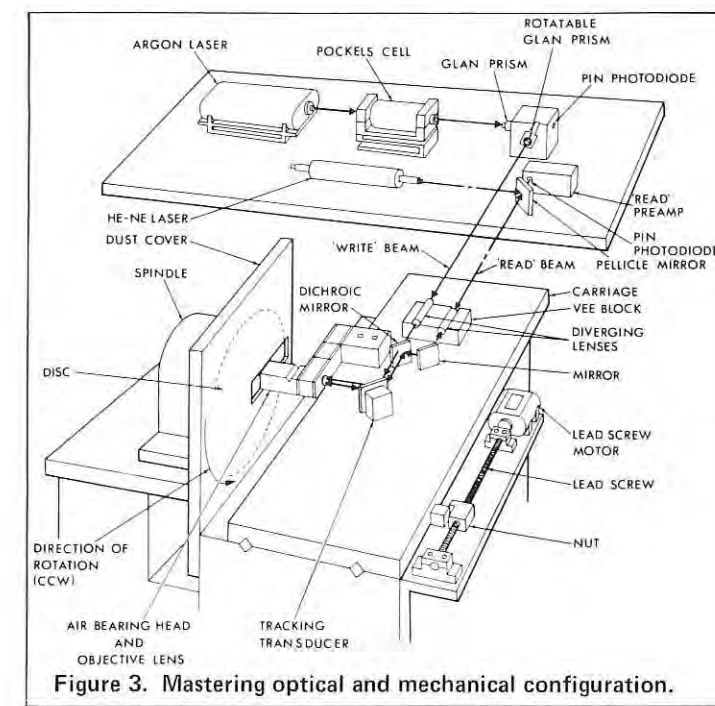

Figure 3. Mastering optical and mechanical configuration.

## 2. REPLICATION

After the master disc has been cut, it must be transformed into a configuration from which replicas can be made. This is done by transforming the essentially "two-dimensional" master record, which consists of holes in a thin metal film, into a "three-dimensional" configuration which can be used to stamp or form inexpensive, plastic replica discs.

### Master Transformation

The master is coated with a photoresist material and is exposed through the rear (under-surface) of the disc. The ultraviolet light source exposes (polymerizes) the photoresist through the information holes. The uncut metal film shields the photoresist where there are no holes. This results in an array of hardened areas which coincide with the initial array of information holes. The unpolymerized photoresist material is then washed away with an appropriate solvent leaving bumps over the holes. Depending upon the photoresist used, the hardening program and other parameters, the height and profile of these bumps may be tailored to optimize the optical contrast between these bumps and the surrounding flat area when they are illuminated by the high numerical-aperture, diffraction limited optical scanning system of the player.

### Replica Forming

The prime method of producing good quality, inexpensive replica discs uses a polyethylene terephthalate material and is a proprietary process at this time. It will be treated elsewhere when the patent circumstances and the proprietary elements permit. It has among its advantages a better quality, tougher record, a shorter production cycle-time, and web or automated belt handling of the entire disc replication process.

An alternate process which has also been employed involves treating the transformed master described above by electroless and electrodeposition to form a metal tool ("stamper") from which replicas are thermoformed, typically from polyvinyl-chloride by a method close to that used to make audio records.

### Post Forming Operations

The plastic discs are finally metallized with a reflective coating and coated with a transparent plastic for protection against

degradation by handling. An alternate process to the final protective coating is to produce the discs using a transparent plastic permitting optical reading of the record through the transparent back side. Due to the limited depth of focus of the read-out optical system, typically  $\pm 1$  micron, scratches or dirt on the surface of the protective coating are out of focus and have no degrading effect on the record playback. Optically read records of this type actually require less care in handling than ordinary audio LPs.

The replicated discs are typically 5 to 10 mils in thickness and may be configured either with information bumps as indicated in the master transformation section or information holes made by forming these bumps into a mating surface—depending upon how many generations or reversals are involved between the transformed master and the final plastic replica. These two configurations are both satisfactory from an optical read-out standpoint.

### 3. PLAYBACK

The playback unit is self-contained and is designed to be connected to the antenna terminals of any domestic American color television receiver to provide playback of replicated videodiscs. It employs an optical technique to read the videodisc that does not require any physical contact between the read head and the videodisc. This non-contact system provides for long life of both the videodisc and the read head and it also permits freeze-framing without any wear penalties. The essential elements of the playback unit includes: (1) an optical system that directs and focuses a low-power helium-neon laser beam to a small read spot on the surface of the videodisc and then collects the reflected optical energy and directs it to a single photo-detector; (2) a means of rotating the videodisc at the correct speed; (3) a means of positioning the read spot on the videodisc surface which acquires and locks on to the spiral data track; (4) a means of maintaining the optical system in focus on the surface of the videodisc; (5) the necessary electronics to process the signals for the television receiver; (6) the controls, control electronics and power supplied to operate and power the unit; and (7) a functional and decorative enclosure to house the unit.

#### Optical System

The playback optical system is shown in Fig. 4. The laser tube has a nominal output power of 1 milliwatt which is single mode (TEM<sub>00</sub>) and linearly polarized. The laser beam is initially directed by two mirrors that are adjustable for alignment purposes. The laser beam is then expanded to fill the back of the objective lens by a plano-convex lens. This beam expanding lens is adjustable along its axis to provide for fine focus of the optical system. The beam is then transmitted through a specially coated beam splitter. The direction of the laser beam polarization is such that most of the beam will pass through the beam splitter. A quarter-wave plate changes the beam polarization from plane to circular. The beam is then directed into the back of the objective by two mirror transducers which consist of mirrors that can be rotated by piezoelectric bender motors. These rotations produce a corresponding motion of the read spot on the disc surface. One transducer is used to move the read spot in a radial direction to provide the high speed tracking corrections required to follow the data track. The other tracking mirror transducer causes the read spot to move in a tangential direction on the videodisc to provide the time base corrections. These high speed tracking and time base corrections are required because of videodisc eccentricity, mechanical vibrations, etc.

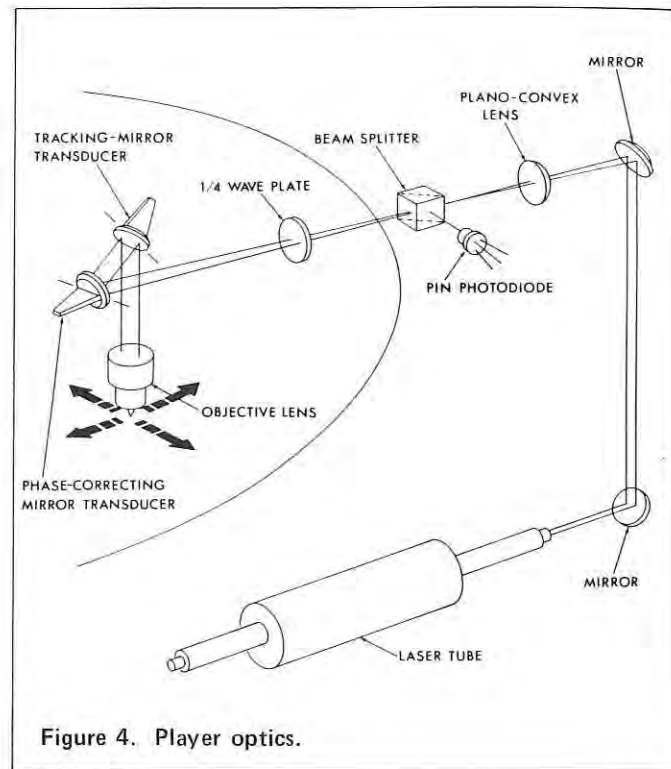

Figure 4. Player optics.

The objective lens which focuses the laser beam to a small spot on the surface of the videodisc has a numerical aperture of .35 and an effective focal length of approximately 12 millimeters. The laser light that is reflected from the surface of the videodisc is collected by the objective lens and returned along substantially the same path that the incoming beam traveled. When the reflected beam passes through the quarter-wave plate it is changed again to plane polarized light, but it is polarized at a right angle to the direction of the incoming laser beam. The reflected beam is then reflected by the beam splitter to the PIN photodiode detector where the optical signal is converted to an electrical signal for processing by the electronics. The use of the plane polarized laser tube, the specially coated beam splitter, and the quarter-wave plate results in a high efficiency optical system that minimizes the reflected signal that is fed back into the laser cavity.

#### Playback Signal-to-Noise Ratio

Measurements were made of the optical efficiency of the player by comparing the energy returned to the PIN diode by a large "land" area on a videodisc and a series of bumps having 2.2 micrometer wavelength, corresponding to an FM frequency of 6.75 MHz at a 3 inch radius. The return from the large land was 10.0%; from a bump 3.0%; from the space between bumps 5.5%. Hence, if a player with a 1 milliwatt laser was reading a 2.2 micrometer recording, a peak to peak signal of .025 milliwatt would return to the PIN diode. This in turn would yield a photocurrent of  $2 \times 10^{-6}$  amp RMS. The noise floor of such a system would be determined by photon shot effects, thermal effects, laser noise and pre-amp noise. Measurements indicate that the thermal and pre-amp noise dominate and are roughly equal. They give rise to a noise current of  $2 \times 10^{-8}$  amp RMS so that the FM SNR would be 100:1 or 40 db assuming perfectly recorded bumps having a 2.2 micrometer wavelength. When demodulated, this FM SNR yields a video SNR of better than 58 db which does not limit the playback quality. The actual playback video SNR is limited by replica disc quality and is presently better than 40 db.

#### Disc Rotation

The videodisc is mounted on a turntable that is rotated at 1798.2 revolutions per minute by an electric motor. The speed of the turntable is sensed by a tachometer that consists of a phototransistor and light emitting diode that are located on either side of an incremental encoder disc that is mounted on the turntable spindle. The belt driven turntable spindle is powered by a universal type motor that is driven from the ac power lines using a triac. The triac is controlled by a phase locked loop control circuit that compares the tachometer output frequency with the counted down output of the 3.58 MHz crystal controlled oscillator in the signal processing electronics. Thus, the spindle drive motor is brought to and maintained at an angular velocity that produces zero mean error between the frequency produced by the tachometer wheel and that of the divided crystal oscillator. This is the rate required to make the frequency of the color signal, and hence the horizontal sync signal, within the range of the time base correction servo.

#### Tracking Servo

Due to possible non-concentricity of the replicated disc and the turntable, replicated disc out-of-roundness and vibration, the read beam and the tracks relative positions do not remain constant. The tracking servo controls the radial position of the read beam in a manner that results in constant read beam position within the track. The ratio of opened to closed loop gain in the control loop would reduce a simple eccentricity of 0.1 millimeters to a reading error of less than 0.15 micrometers. The maximum trackable eccentricity is about 0.25 millimeters, but as a practical matter, the replicated discs will have eccentricities less than half that value.

Since the overall development objective was aimed at a reasonably priced consumer product, a simple tracking and information reading system requiring only a single photo-surface for all functions combined was developed (after considering a variety of techniques). This not only minimizes the cost of photo-detectors and their associated electronics, but even more importantly, reduces to one the number of optical paths that must be critically aligned and registered during the manufacturing process. The tracking servo technique is illustrated in Fig. 5. A single PIN photodiode is used to recover the tracking servo and video signals. A limited bandwidth, high gain dc pre-amp outputs a signal that is a function of read beam position within a track. It is clear that this signal is also directly proportional to laser power output. Since laser output power is influenced by a variety of conditions, some means of compensation is required for long term stable tracking. A portion of the direct beam is directed onto an inexpensive silicon solar cell with the cell output used as a compensating signal in the servo pre-amp, allowing the tracking servo to respond only to the read beam position within the track.

A dc bias, whose value represents position within the track, is summed with the pre-amp output and applied to the amplitude and phase compensation circuit which is designed to make the servo loop stable at high gain. The compensation deviates somewhat from normal control theory techniques because of the need to compensate the high Q of the piezoelectric mirror transducer that changes the radial position of the read beam. The output of the compensation circuit then is applied to the phase splitter which feeds the transducer drive amplifiers. When the loop is closed, the mirror transducer constantly positions the read spot with respect to the track so that the average reflected signal corresponds to the set dc bias.

There is a leadscrew drive system which moves the read head on a near radial path at the nominal pitch rate (2 micrometers/revolution). A secondary servo loop samples the low

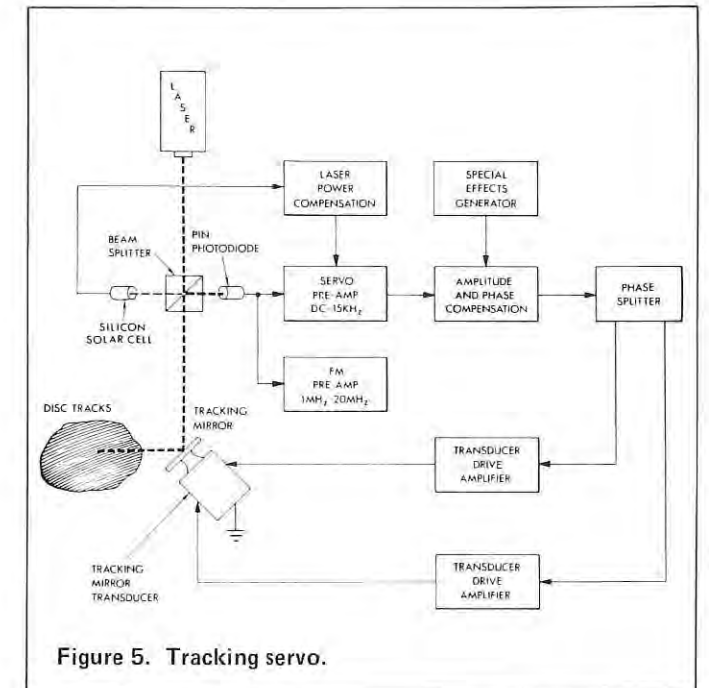

Figure 5. Tracking servo.

frequency portion of the servo signal to make the average head radius equal the read spot radius during playback.

To implement stop motion and other special effects a means of causing the read beam to "jump back" one track, at a predetermined time, is required. This is done by injecting into the tracking servo loop a modified impulse function with sufficient area to move the read beam one track (2 micrometers). Due to the dynamics of this process several compensating signals are also summed in the servo loop to keep the read beam positioned properly within the track immediately after "jump back."

#### Time Base Correction Servo

In the normal television receiver the chrominance and horizontal sync circuits are very intolerant of time base errors in the composite video signal. To assure proper playback a corrective motion is applied to the read spot in the direction of the information track. The sources of time base error are the same as for the tracking error. The frequency of the burst signal is used as the basis of the control action. With the burst signal corrected all other portions of the video will be correct. The time base correction techniques is illustrated in Fig. 6.

The chrominance signal is extracted from the video and applied as one input to a phase detector. The other input is derived from a narrow range crystal VCO operating at the nominal color burst frequency. A zero order hold samples the phase detector output during the burst time-slot. Thus, the output signal has an amplitude proportional to the phase difference between the video burst signal and the VCO. This signal is then applied to an amplitude and phase compensation circuit (similar to the tracking servo) to stabilize the servo operation. The output of the compensation circuit is applied to a phase-splitter and then to the transducer drive amplifiers. The mirror transducer constantly positions the read beam such that the video burst frequency is exactly identical to the VCO.

Since the mirror transducer has finite dynamic range, static errors must be corrected by another technique. Another loop has been added to correct this problem. A signal containing the very low frequency components of the main servo loop is applied to the referenced VCO in a manner to cancel the static errors.



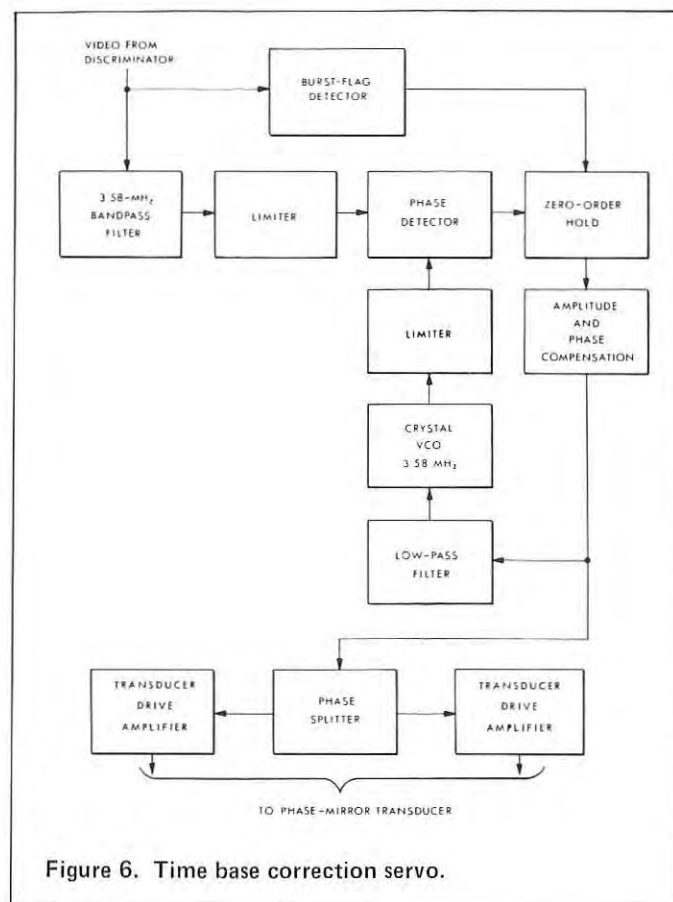

Figure 6. Time base correction servo.

#### Reading Height Regulation

The videodisc is maintained at the focus of the optical system by means of a vacuum controlled aerodynamic reading head that carries the objective lens. The thin videodisc is separated from the turntable by a film of air when the turntable is rotating at speed. This film is due to the radial outward flow of air drawn through a circle of ventilating holes bored in the turntable just outside of the clamp ring. The air film decreases the coupling between the videodisc and the turntable enough to permit a vacuum applied to the face of the reading head to make a buldge in the surface of the thin videodisc.

The distance between the reading head and the surface of the videodisc is stabilized by the balance between the aerodynamic forces tending to push the disc away from the read head and the vacuum that tends to pull the disc toward the read head. The separation between the read head and the videodisc is controlled by vacuum pressure and air flow into the vacuum port on the read head. This fail-safe, vacuum controlled, aerodynamic reading head operates with a head-to-disc spacing of greater than 1 mil and provides stiff head-to-disc coupling that maintains the distance between the objective lens and the thin replicated videodisc to within 1 micrometer which is adequate to keep the optical system in focus.

#### Discriminator and Drop-out Compensator

Because the FM encoded signal recorded on the disc is video in the NTSC format with the sound at 4.5 MHz, the signal processing electronics can be relatively simple. As shown in Fig. 7, the video signal is first recovered with a discriminator and then used to modulate an oscillator tuned to an unused TV channel. A more detailed description follows: The FM encoded information from the PIN photodiode is amplified by a wide band, low noise pre-amp located near the photodiode. The signal is limited and applied to the FM drop-out compensator.

Due to the nature of the Disco-Vision record and reproduce process, drop-outs tend to be caused by a missed half-cycle of the FM carrier. This requires a different compensation technique than that for systems such as magnetic tape where the duration of the drop-out is generally a large portion of a horizontal line. A missed half-cycle of carrier looks like a large decrease in instantaneous frequency so that the discriminator produces a whiter than white impulse in the video signal. If not compensated, the drop-out would produce a very distracting white spot in the TV image. To reduce the viewers awareness of the drop-out, the playback electronics includes an FM drop-out compensator which detects the missing half-cycle and synthesizes a signal to replace it. Although it contains no information, the synthetic pulse greatly reduces the visibility of the drop-out. This entire section, including the multiplying type of discriminator, is implemented with digital techniques for cost savings and ease of alignment.

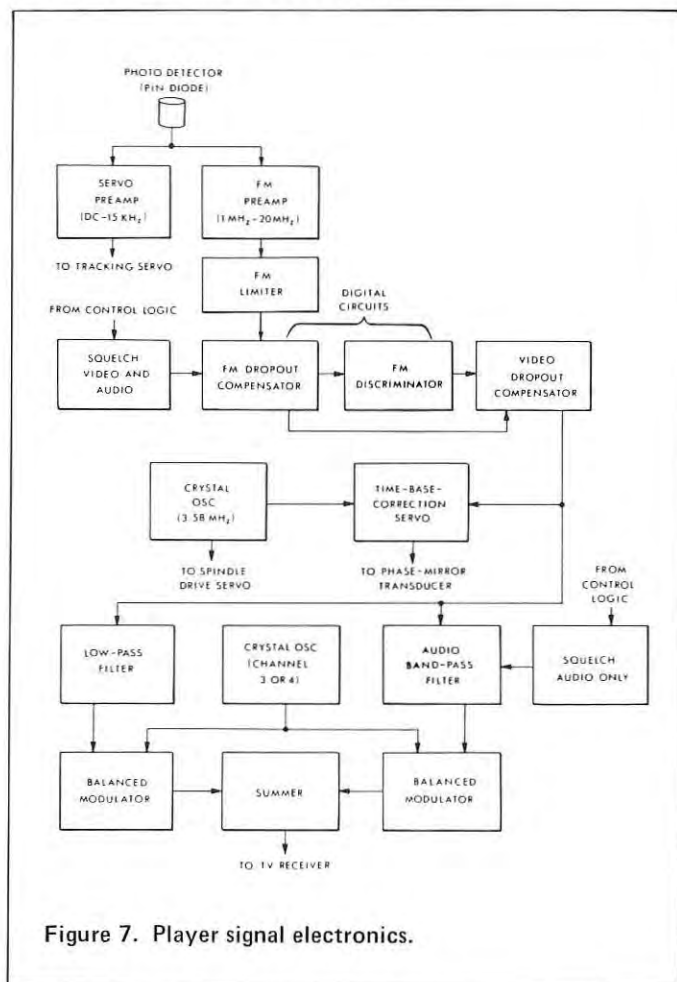

Figure 7. Player signal electronics.

On rare occasions drop-outs with a duration of several cycles of carrier are encountered. When this happens compensation is most easily done in the video domain. This is accomplished by passing the video signal through a zero order hold which operates normally in the sample mode. When a multiple cycle drop-out is detected, the circuit is switched to the hold mode. This supplies the last sampled value of luminance signal for the duration of the drop-out.

After discrimination what results is a full bandwidth NTSC composite signal complete with audio subcarrier.

The Disco-Vision recording and reproducing system, if not limited by the TV receiver, produces an image with more than 450 lines of horizontal resolution (on the basis of two lines of horizontal resolution per cycle of video signal) and video signal-to-noise ratio of greater than 40 db in the replica disc.

# W-J's Laminarflo<sup>®</sup> Gun CRT's Can Meet The Need!

Does your CRT display need:

- Increased Brightness?
- Reduced Grid Drive?
- Improved Resolution?

Watkins-Johnson's Laminarflo<sup>®</sup> electron gun CRT's have achieved spot sizes as small as 0.8 MIL and brightness in excess of 20,000 Ft.-Lamberts. W-J's tubes range in size from one inch (round) to 25 inches (rectangular).

CRT products currently offered by W-J are finding application as:

- Projection Tubes
- Computer Display Tubes
- Ruggedized Tubes
- Flying Spot Scanner Tubes
- Recording Tubes
- Radar, Sonar and Multisensor Tubes

Find out how W-J's Laminarflo<sup>®</sup> gun CRT's can enhance the effectiveness of your display by contacting the Watkins-Johnson Field Sales Office in your area or by phoning CRT Applications Engineering in Palo Alto at (415) 493-4141, ext. 386.



Watkins-Johnson—U.S.A.: 3333 Hillview Ave., Palo Alto, CA 94304 • (415) 493-4141 • TWX: 910-373-1253 • Telex: 34-8415 • Cable: WJPLA • 700 Quince Orchard Rd., Gaithersburg, MD 20760 • (301) 948-7550 • TWX: 710-828-0546 • Telex: 89-8402 • Cable: WJCEI • United Kingdom: Shirley Ave., Windsor, Berkshire SL4 5JU. England • Tel: Windsor 69241 • Cable: WJUKW-WINDSOR • Telex: 847578 • West Germany: 8033 Planegg, Muenchenerstr. 17 • Tel: (089) 859-9441 • Cable: WJDBM-Muenchen • Telex: 529401 • Italy: Piazza G. Marconi, 25 00144 Roma-EUR • Tel: 59 45 54 • Cable: WJROM-ROMA • Telex: 60117

DESIGNERS  
formulas, curves, diagrams

RESEARCHERS  
tables of optical  
parameters

BUYERS  
the world's  
largest  
selection  
of optics  
from stock

USERS  
large variety  
of optical  
components

ENGINEERS  
design  
assistance  
complete  
specifications

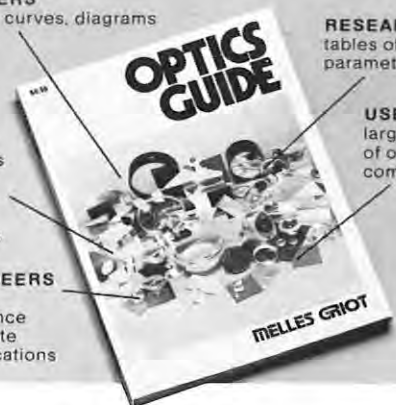

**At last...  
the complete Optics Guide.**  
Anyone can design or specify optical systems  
using the new Melles Griot Optics Guide.

Write stating your area of application and the  
types of optical components you're now using, and  
we'll send you this new Guide free of charge.  
(Regular Price \$8.50).

INDUSTRIAL & SCIENTIFIC OPTICS  
**MELLES GRIOT**

(formerly Optical Industries)

3006 Enterprise St. E., Costa Mesa, Ca. 92626 (714) 556-8200  
388 Main St., Dept. 3, Danbury, Conn. 06810 (203) 792-2002  
Nieuwe Kade 10 Arnhem, Holland 085-229011

Circle Readers Service Card No. 54

## CRT DESIGN PROBLEM?

*We have the components and  
the performance you need.*



CRT CAMERA & DISPLAY COMPONENTS  
**WASHBURN LAB., INC.**  
115 TOMPKINS AVE., PLEASANTVILLE, N.Y. 10570  
(914) 769-5774

### R.E. Modulator

The R.F. modulator is illustrated in a portion of Fig. 2. The audio subcarrier and the video signals are separated by filters. Each is then applied as one input to a pair of balanced modulators. The other pair of inputs are derived from an oscillator tuned to the carrier frequency of the unused TV channel selected. The outputs of the modulators are then summed to form the RF signal for application to the antenna terminals of a TV receiver. A switching arrangement linked to the player power switch, connects normal TV antenna to the TV receiver when the player is not in use.

### Operating Controls

The operating controls for the playback unit are located in a control panel on the top front left corner of the unit. The control panel consists of a slide switch to turn the unit on and five push button switches labeled "play," "stop," "in," "out," and "reject". The power to the playback unit is turned on by the slide switch. The slide switch also disconnects the television antenna from the television receiver and connects the television receiver to the playback unit.

The "play" push button is used to initiate the start of the playback sequence. When it is depressed and the cover on the unit is closed the turntable starts to rotate and the player arm moves to position the read head over the start of the program on the video-disc. When the turntable is up to speed and the player arm is in position, the player will automatically play through the entire program on the videodisc unless it is interrupted by pushing one of the other push buttons. Upon completion of the program the turntable will automatically stop and the player arm will move clear of the videodisc.

The function of the "stop" push button switch is to stop the motion of the player arm and "freeze" the scene of the television screen to a single TV frame. This single TV frame will then continue until interrupted by pushing another button. The audio is suppressed during this stop motion sequence.

The "in" push button switch is used to translate the player arm in toward the center of the disc at approximately 100 times the normal playing speed for fast scanning to another part of the program. This fast scanning continues as long as the push button is depressed or until the program is completed. The function of the "out" push button switch is similar to the "in" switch except it translates the player arm back toward the start of the program on the disc. The optical, non-contact nature of the system permits fast scanning to be performed at will with no wear or degradation of the disc. It may be the ideal way for the consumer to locate a desired band for playback since even with the 100 times speed up in the fast scan arm translation, picture content can be recognized on the TV screen.

The function of the "reject" push button is to terminate the program and when depressed will stop the turntable and move the player arm clear of the videodisc.

### Special Effects and Applications

Because of the lack of physical contact inherent in this optical system and because information or frames within the disc may be random accessed very rapidly, many applications in addition to home entertainment are possible. These include archival storage of documents and facsimiles; audio-visual encyclopedias, dictionaries, catalogs, etc., that may be accessed immediately on a frame address basis; teaching machine and educational applications which involve inter-active programming with addressable sub-routines and branching and many other applications where data, pictures, motion or general audio-video information must be stored inexpensively

and accessed flexibly and rapidly. To this end initial work in frame numbering and coding and search programming has been carried out.

### Frame Number Encoding

This is accomplished by placing within each vertical interval a coded digital word containing the following:

- Pseudo Random Sync Words
- Parity Check
- Five Decimal Digit Frame Number
- Field I.D.

The information is coded in a self-clocking format to simplify the data recovery process.

### Search Program

The digitally encoded frame identification data is recovered with a self-clocking decoder. The data is stored in a buffer and updated every vertical interval. A parity check and pseudo random sync codes are used to ensure only valid data is used. A five digit display presents the number of the frame being viewed.

When the search mode is initiated, logic compares the present frame number with the desired frame number. The direction in which the desired frame lies is determined, and the leadscrew servo is set into fast scan in that direction. The digital data is read during the fast scan until passing the desired number. If the initial scan was in reverse, the leadscrew stops, and the player resumes normal real-time play until the desired frame is reached. If the initial scan was forward, the leadscrew reverses direction after passing the selected number and continues until the number is again passed. This places the read beam again ahead of the desired frame. The leadscrew again stops, and normal real-time play is resumed until the desired frame is reached. When the desired frame is reached, the logic switches to the stop motion mode where the desired frame can now be viewed. With the present player, this technique permits access to any frame out of about 36,000 within a few seconds. The search logic has the capability to perform other special effects. They are forward and reverse slow-motion (variable rate), and single-frame step forward and reverse.

### ACKNOWLEDGEMENT

The techniques reported in this review are the result of developments carried out by Department Heads John Winslow, James E. Elliott, and Ray Dakin, and their associates on the MCA Laboratories staff.

### about the author



Kent D. Broadbent, Vice President of MCA DISCO-VISION, Inc., is director of MCA'S videodisc research program. He is a specialist in the field of information storage and processing and his career as a research scientist and technical manager spans 21 years.

Prior to his affiliation with MCA, Mr. Broadbent was president of Broadbent Laboratories, Inc., and before that was director of American Systems, Inc.'s solid state division. Previously, he was head of the subsystems, components and devices section of Hughes Research Laboratories. He has also served as a technical consultant to Hughes Aircraft Company, North American Aviation, Lockheed Electronics and MCA Inc.

Mr. Broadbent has a B.S. in physics and mathematics from Brigham Young University and an M.S. in physics from Case Institute of Technology. He also completed extensive additional graduate work in physics and electronics.

Mr. Broadbent holds 18 patents and has published papers in technical journals on advanced information processing systems and solid state research.

# HIGH VOLTAGE POWER SUPPLY MODULES FOR CRT, PMT, SEM, COM AND SPECTROSCOPY

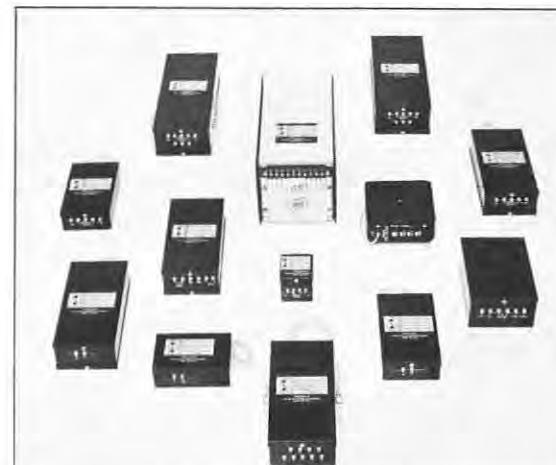

### SUPER-REGULATED

SRM Line — Models through 30KV and 30 Watts.  
Fully adjustable from near zero to Max rated voltage.  
Regulation (line and load): 0.001%; Ripple: 0.001% RMS.  
Perfect for SEM, COM and PMT applications

### WELL-REGULATED

WRM line — Fully adjustable models to 30KV, 30 Watts.  
Line regulation: 0.01%;  
Load regulation: 0.05%;  
Ripple: 0.01% / watt p-p

FRM line — "SLOT" supplies Models to 30KV, 30 watts  
Line regulation: 0.01%  
Load regulation: 0.05%  
Ripple: 0.01% / watt p-p

### REGULATED

RM line — Fully adjustable Models through 30KV, 10 watts  
Line regulation: 0.01%  
Load regulation: 1% / watt  
Ripple: 0.1% RMS/watt

FRM line: "Slot" supplies Models to 30KV, 10 watts  
Line regulation: 0.01%  
Load regulation: 1% / watt  
Ripple: 0.1% RMS/watt

### PROPORTIONAL

UM Line — Models through 24KV, all units capable of 1.5 watts output, output proportional to DC input (0-24V Full scale). Load regulation: 15%

### MULTIPLE OUTPUT CRT SUPPLIES

RMC Line; Anode: 10, 12 or 15 KV @ 200ua  
G-2: +400V @ 1mA  
G-1: -100V @ 1mA

WRMC: Anode: 30KV @ 1mA  
Focus: 4-7KV adjustable  
Grid: 1.5KV @ 1mA

Excellent Regulation, Ripple and Transient Response



**SPELLMAN**  
HIGH VOLTAGE ELECTRONICS CORPORATION

1930 ADEE AVENUE, BRONX, NEW YORK 10469  
(212) 671-0300 • TWX: 710-593-4135

See Us At Booth #470  
at the SID Exhibit, Beverly Hills, May 4-6

Circle Readers Service Card No. 56

# The RCA "SelectaVision" VideoDisc System

The RCA "SelectaVision" VideoDisc has been developed to satisfy the need for a pre-recorded video storage and playback system suitable for the home environment. To be suitable for the consumer market, such a system must be reliable, easy to operate, provide a high quality color picture on a standard color TV receiver, have a wide selection of program material, and be low in cost. The RCA VideoDisc system has these qualities. The techniques by which they are achieved are discussed in the following paragraphs.

Three key design decisions led to the simplicity and low cost of the RCA approach:

1. The use of a grooved disc to permit the disc itself to provide positive tracking of a stylus along the signal path by purely mechanical means, eliminating the need for any expensive servo loops.

2. The use of capacitance pickup from a metallic electrode deposited on the stylus to retrieve the signal. The advantage here is that the stylus is easy and inexpensive to fabricate in comparison to any other technique for retrieving recorded signals from the disc. (The capacitance pickup is capable of resolving signal elements smaller than the wavelength of visible light, permitting RCA to take full advantage of the high density recording capability of the electron beam recording technique RCA has developed.)

3. The choice of a lower rotational speed of 450 rpm. Important advantages are: Problems of vibration due to unbalance of the disc or rotating parts of the player are significantly reduced in their effects. Errors in signal timing that might result from warp or eccentricities of the disc occur at a frequency that is easier for the television receiver to compensate for. More importantly, a simple and inexpensive electromechanical device, the "arm stretcher," can be used at this lower rotational speed to reduce time-base errors thereby permitting playback into receivers with the relatively slow horizontal synchronizing circuits typical of most U.S. and European made receivers, without requiring modification of those receivers. A disadvantage is that

there are 4 TV frames recorded during each revolution of the disc, making it less suitable for stop-action and slow-motion effects.

With the exception of the stylus, the RCA VideoDisc player is fabricated almost completely from conventional and familiar components of types that have been in production for many years in consumer products. As indicated above, the use of a grooved disc and capacitance pickup stylus contributes greatly to the simplicity and low cost of the RCA VideoDisc system. An obvious question is "What is the playing life of the disc and the stylus?" The discs have routinely exhibited playing life in excess of 500 plays before visible signal degradation. The life of the sapphire stylus is expected to be 300 to 500 hours of playing time. The stylus and stylus arm are housed in an inexpensive cartridge, easily replaceable by the user in the home.

In a new medium for entertainment and self-education, long playing time per disc is an important consideration. Each RCA disc is capable of reproducing a full hour of recorded program, 30 minutes on each side. Virtually any feature-length movie can be sold in this form as a two-disc itself is familiar in form. It is a 12-inch disc composed of vinyl copolymer materials of the type used in an ordinary audio disc. The metallic and dielectric coatings necessary for playback by means of a capacitance pickup give the disc a distinctive shiny appearance and can be inexpensively applied in an automatic continuous process.

## Information on the Disc

The RCA VideoDisc utilizes a spiral groove of roughly circular cross section with a pitch of 5555 grooves per inch. The information is recorded as transverse slots of varying width and separation recorded into the bottom of the otherwise smooth groove and is read out by a stylus which rides in the groove and detects the passage of the relief pattern under it as the disc turns. Figure 1 shows a model of the record surface and the tip

of the stylus riding in the groove. In playback, the disc turns at a constant speed of 450 revolutions per minute. Luminance, chrominance, and audio signals are encoded in the zero crossings of the relief pattern pressed into the disc. As will be described in more detail later, an electron beam is utilized in recording the signal slots. The stylus, which is composed of a main body of sapphire shaped to fit the groove and a thin metal electrode perpendicular to the groove, detects the relief pattern in the record by changes in capacitance between the tip of the electrode and the metallic coating of the record surface as indicated in Figure 2.

In order to conserve bandwidth, the chrominance signal is combined with the luminance signal in a system which we call "Buried Subcarrier Color Encoding." This system depends for its operation on the fact that a television video signal, to a large extent, repeats at horizontal line rate and thus has an energy spectrum with peaks at multiples of line frequency. Such a signal can be passed through a comb filter with peaks at multiples of line frequency with little degradation. The luminance signal is passed through such a comb filter as indicated in Figure 3. This leaves nulls in the energy spectrum, at off multiples of half line frequency, into which the chrominance is encoded. One of the nulls (1.53 MHz) is chosen for the suppressed subcarrier frequency for quadrature modulation by R-Y and B-Y chrominance signals. Since these signals also repeat at line frequency, the resulting side bands occur at multiples of line frequency away from the carrier and thus also fall on the nulls of the luminance comb filter. The modulated chromance signal is passed through a comb filter with transmission peaks at odd multiples of half line frequency, which are interspersed between the peaks of the luminance filter. The comb filtered luminance and chrominance signals are added together to provide a composite video signal with a total bandwidth of 3 MHz which is recorded on the disc as an FM signal, peak white recorded as 6.3 MHz, black as 5.0 MHz, and sync tips as 4.3

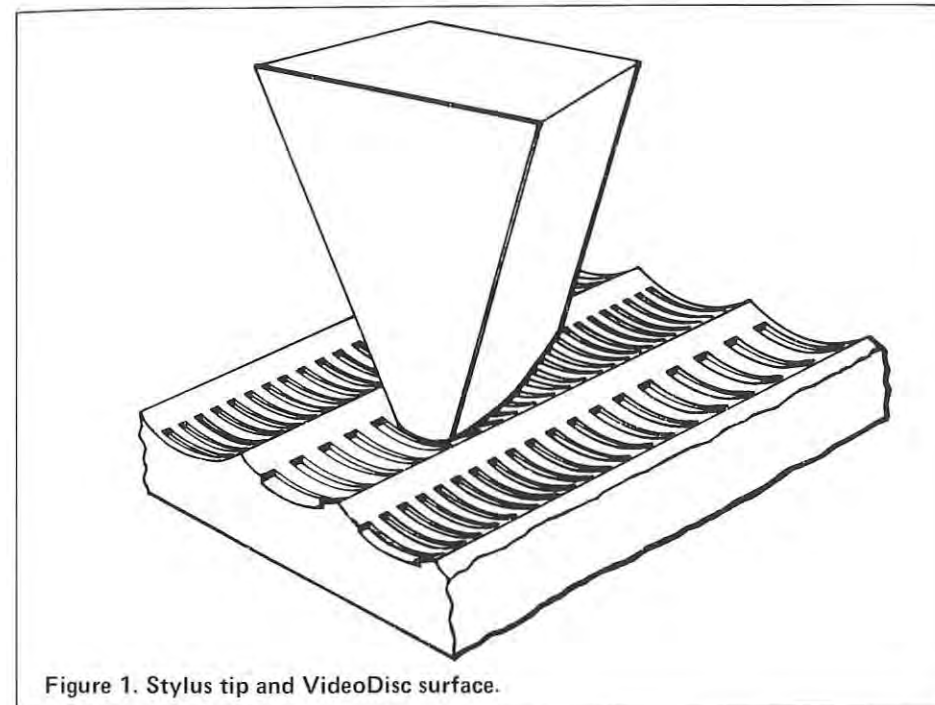

Figure 1. Stylus tip and VideoDisc surface.

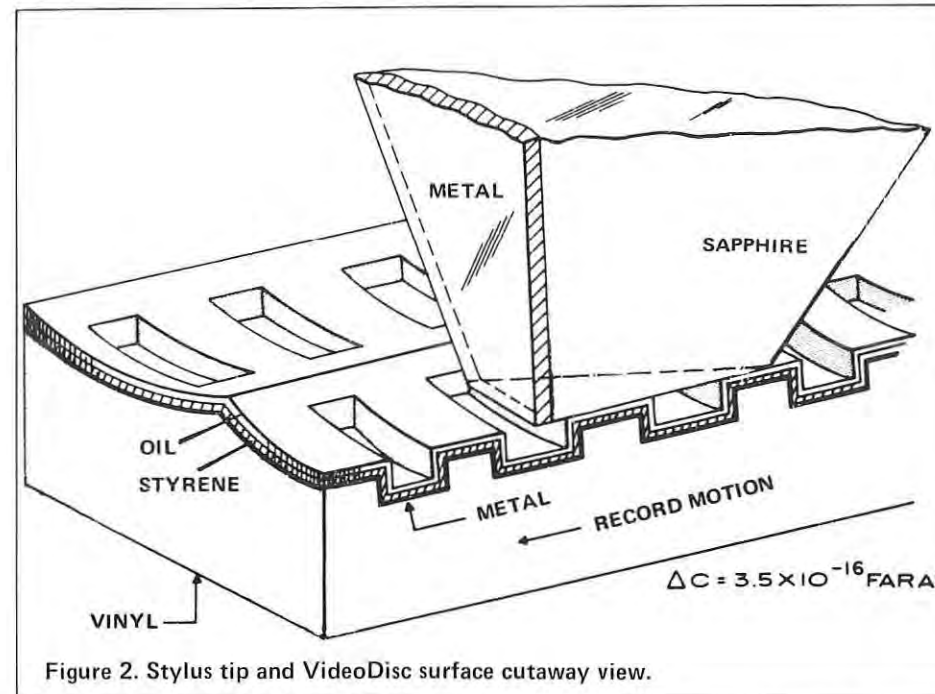

Figure 2. Stylus tip and VideoDisc surface cutaway view.

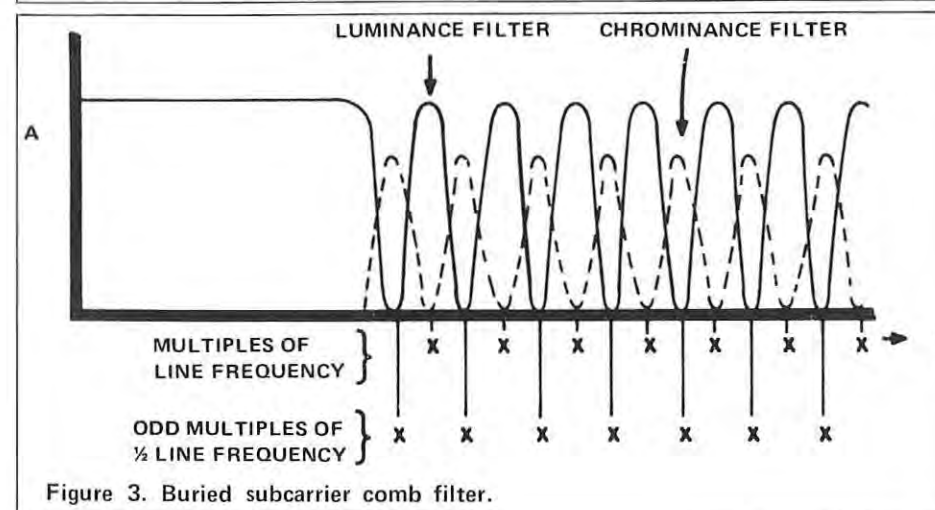

Figure 3. Buried subcarrier comb filter.



## DOES GLARE MAKE YOUR CRT DISPLAY HARD TO READ?

Although brightly lighted offices and CRT computer terminals are incompatible, they often go together. CRT faceplates on which Metavac anti-reflection coatings have been vacuum deposited effectively reduce glare. Aircraft instruments, laser range finders, beamsplitters and optical communications equipment are some of the other applications for these high efficiency coatings. Metavac has an anti-reflection coating for virtually any requirement — and 30 years of experience in thin film coatings for optics and electronics. Write for technical data.



Thin Film Coatings for Optics and Electronics

Circle Readers Service Card No. 57

MHz as indicated in Figure 4. On playback, after suitable demodulation, the chrominance and luminance are separated by appropriate comb filters and then recombined into a standard NTSC color signal. The audio is included in the recorded signal by duty cycle modulation of the composite video FM signal. Without the audio, the composite video FM signal has a duty cycle of 50%, i.e., the lands are as wide as the slots. The audio is included by deliberately modifying the video FM signal so that the duty cycle is not 50%, i.e., by making the lands periodically wider and narrower than the slots. This is accomplished by frequency modulating suitable carriers with the audio signals, adding the frequency modulated sound carriers to the composite video FM signal and passing the sum signal through a limiter. The result is the duty cycle modulated composite video FM signal which is recorded on the VideoDisc.

With the parameters that have been chosen for the RCA VideoDisc (450 rpm, signals as high as 6.3 MHz, and an inner groove radius of 3.28 inches), the shortest recorded wavelength is about 0.6  $\mu\text{m}$ . When duty cycle modulation is added, the narrowest recorded slots are about 0.25  $\mu\text{m}$ . It has been found convenient to record slots of this width by means of a finely focussed beam of electrons impinging upon electron beam sensitive material (similar in many respects to the more conventional photo-resists).

The disc master upon which recording is done is made by mechanically cutting trapezoidal cross-section grooves in a copper coated aluminum disc, applying electron beam sensitive material in dilute solution to this disc, and letting the sensitive material sag into the grooves as the solvents evaporate as shown in Figure 5. The net result is a disc coated with electron beam sensitive material with the desired spiral groove pattern in its surface.

The coated disc is mounted on a turntable in a vacuum in an electron beam disc recorder so that it can both rotate and translate under a modified scanning electron microscope column as indicated in Figure 6. The electron microscope gun and lenses provide a finely focussed beam of electrons at the surface of the master disc. Both deflected pencil beams and undeflected fan shaped beams have been used for this purpose. In either case, the beam is turned on and off to provide the exposure required. Positive acting sensitive materials are used, which is to say that those portions of the material which are struck by the electron beam can be removed by subsequent development.

Rotation of the turntable is achieved

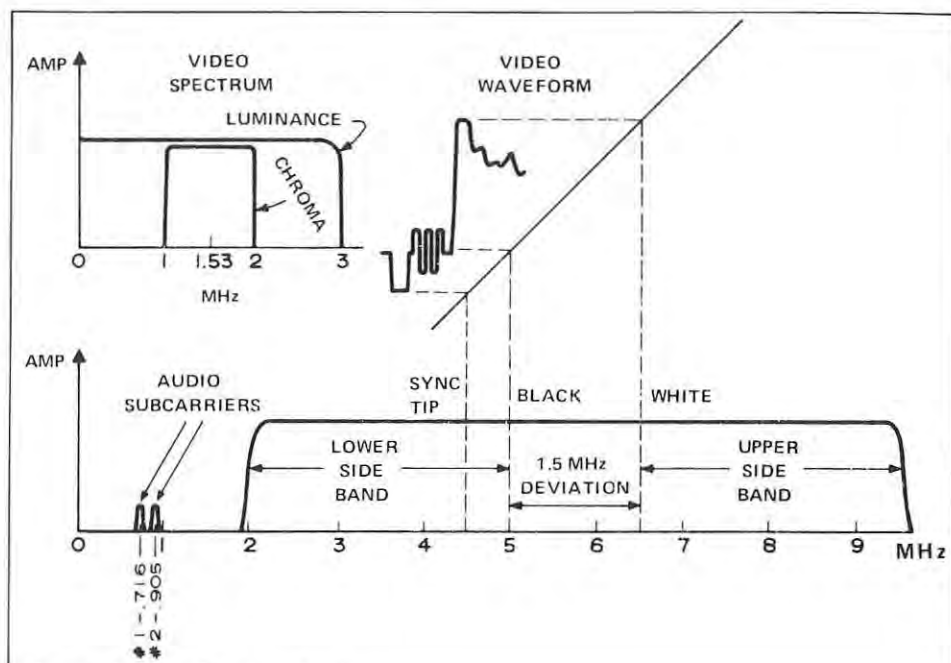

Figure 4. VideoDisc spectrum.

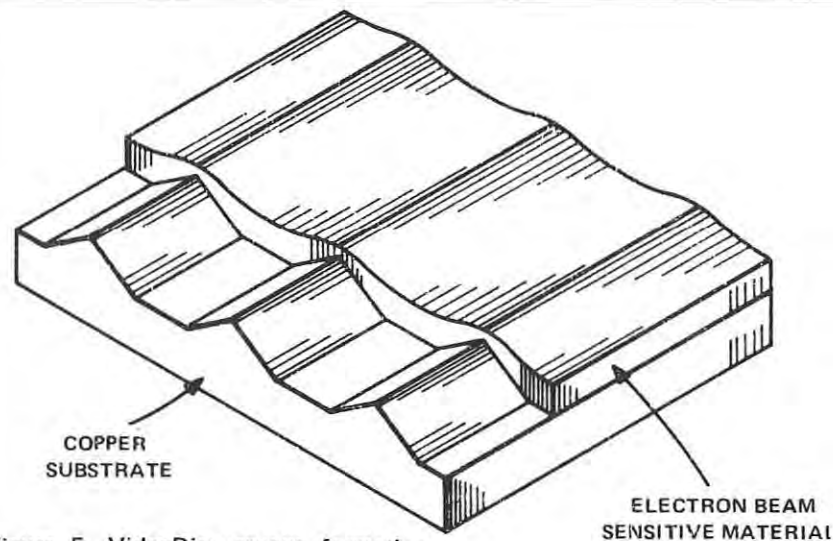

Figure 5. VideoDisc groove formation.

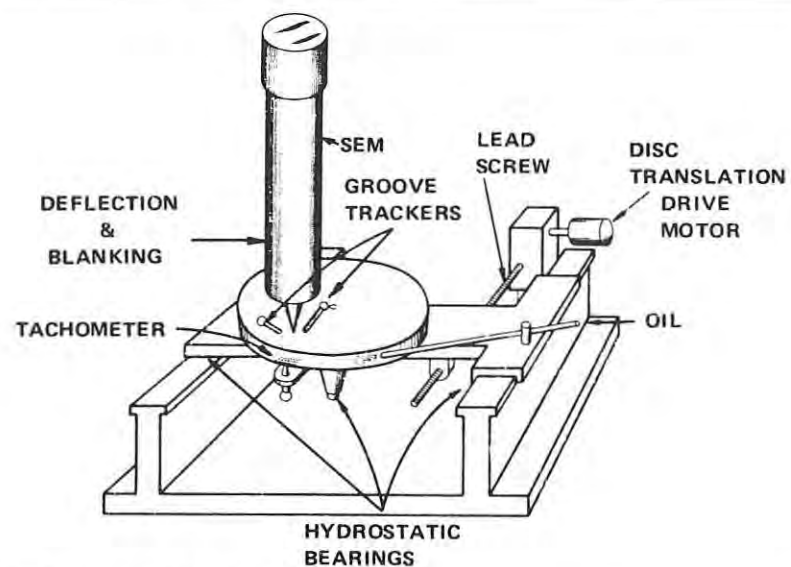

Figure 6. Electron beam disc recorder.

by directing a jet of oil at its periphery and causing it to turn as a turbine. Speed of rotation is measured by an optically interrogated tachometer disc. Speed is controlled by supplying more or less oil to the turbine drive.

As the turntable rotates, it is also translated by a lead screw so that the electron beam remains centered on the pre-cut grooves of the master disc. The position of the groove relative to the electron beam is determined by electrons back scattered from the groove walls and collected by suitable groove tracking sensors. An unbalanced condition in the groove tracking sensors causes corrective signals to be applied to beam deflection circuits and the lead screw drive.

Limitations imposed on the recording system by less-than-desired beam energy and less-than-desired resist sensitivity have dictated that recordings be done at rates which are less than real time. Most RCA records to date have been recorded at 20X below real time, several have been recorded at 5X below real time, and a few have recently been recorded at real time. The increase in recording speed has been achieved mostly by modifications in the electron beam source and its utilization so that more energy is available for exposure. We are currently refining our real time exposure capability in our research laboratories and plan that all of our recording will be done at real time speed at time of product introduction.

After exposure and development, the master disc has the relief pattern which is desired in the final records, as indicated in Figure 1. Metal parts are made for stamping records by the same methods as used for audio records. Electroless plating of the recorded master plus further build-up by electroplating produces a negative metal master. This is replicated by electroplating to provide a positive copy (variously called a mold or a mother). The mold is replicated by electroplating to provide a stamper which is used to press records. While fanout numbers are not yet fully established, it is estimated that one recorded master will produce one metal master, the metal master will produce 10 molds, each mold will produce 10 stampers, and each stamper will produce 1250 records. Thus, each recording operation may result in 125,000 records.

The final step in the manufacture of the records is the application of metal (by vacuum sputtering), styrene (by glow discharge), and oil (by an evaporation process). The metal and styrene enhance the electrical capacitance variations experienced by the stylus-record interface, and the oil provides lubrication to increase both record and stylus life.

## Playback of Recorded Information

As mentioned earlier, playback of the recorded information is by means of a stylus, riding in the groove, which experiences a change in capacitance as the relief pattern of the record passes under the tip of the stylus. The stylus-record capacitance is made part of a resonant circuit (at about 915 MHz), the turning of which is varied by the stylus-record capacitance variations as indicated in Figure 7. When driven by an oscillator of suitable frequency (on the skirt of the resonant curve), the variable frequency resonant

turntable is achieved by driving with a synchronous motor locked to the power line. Small perturbations in playback speed, due to synchronous motor hunting, record off centering, etc., are corrected by an arm stretcher. This unit consists of a small electromechanical transducer (similar to a moving coil loudspeaker element) which drives the stylus arm back and forth along its long dimension, parallel to the record groove. If the record tends to run too slowly, the stylus is pulled toward the transducer to in-

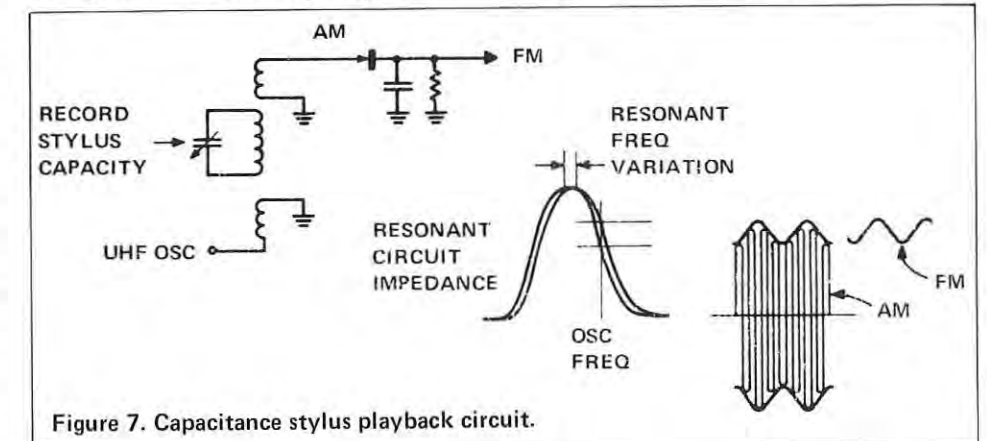

Figure 7. Capacitance stylus playback circuit.

circuit will provide a variable impedance and thus a variable amplitude of the oscillator signal as it passes through the resonant circuit. The amplitude modulation is stripped by a diode detector to provide a signal which rises and falls with the passage of the slots in the record under the stylus. This FM signal is demodulated to provide the composite video signal mentioned earlier. The audio signals are recovered by appropriate filtering followed by FM detectors.

Average speed control of the playback

increase the relative speed between stylus and record, and if the record runs too fast, the stylus is pushed away from the transducer to reduce the relative speed. Error signals to control the arm stretcher are derived from measurements of the color burst frequency as the record is played.

Defect compensation is provided by a 1 H delay line, appropriate sensing circuitry, and video switches to substitute the video from a previous line whenever defects occur on the present line.

## System Parameters

A summary of the pertinent parameters of the RCA VideoDisc system follows:

Record Diameter	12 inches
Record Thickness	0.07 inches (at center and outside rim)
Rotation Rate	450 rpm
Center Hole Diameter	1.5 inches
Recorded Band	2.44 inches wide (5.72 to 3.28 inches radius)
Play Time	30 minutes each side 60 minutes total (two sides)
Recorded FM Signal	4.3-6.3 MHz
Luminance Bandwidth	3.0 MHz
Chrominance Bandwidth	0.5 MHz
Video Signal to Noise Ratio	>40 dB
Audio Carriers	716 and 905 kHz
Audio Bandwidth	15 kHz
Audio Signal Frequency Deviation	$\pm 50$ kHz
Audio Signal to Noise Ratio	60 dB approximately

# '76 NCC Landmarks in Data Processing

Mark the place and time... New York City, June 7-10... for the National Computer Conference, a landmark event for computer professionals, applications specialists, users, business managers, administrators, educators, and others concerned with data processing.

The '76 NCC will be your one opportunity during the Bicentennial Year to hear leading experts, to see and evaluate the latest in products and services, and to confer with colleagues, customers, and industry representatives... all in one place at one time.

More than 100 information-packed sessions will analyze the latest trends and issues affecting performance, productivity, and profit. The program sessions will be organized into 10 or more major areas, or "tracks," running throughout the Conference and covering such topics as complex systems, hardware technology, software and components, system architecture, computer communications, management concerns, education and training, advanced applications, and societal issues.

In addition, the program tracks will include more than 20 special one-day "mini-symposia," each consisting of four sessions. In advanced applications, for example, mini-symposia will cover medicine and health care, banking and electronic funds transfer, and business systems. Other symposia will include such key topics as government policy, control instrumentation, performance measurement, standards, networking, privacy, legal considerations, and word processing systems.

And there's much more. The world's largest lineup of data processing products and services will be displayed on three floors of the New York Coliseum.

Included will be the latest offerings from more than 275 organizations, ranging from mainframes, minicomputers, peripherals, packaged programs, and publications, to micro-processors, memories, terminals, systems, and services. Among the exhibitors will be such leading companies as Ampex, Control Data, Data General, The Harris Corporation, Hewlett-Packard, IBM, ICC/Milgo, Lear Siegler, Modular Computer Systems, NCR, Perdec, and Xerox.

Conference registrants will also have the opportunity to attend five special Plenary Sessions featuring leading spokesmen from industry, the computing profession, and major user areas. And, for an additional fee, they will be able to choose among a number of in-depth Professional Development Seminars dealing with advanced techniques for cost-effective computer usage.

In addition, a Pioneer Day Program will honor individuals from the Moore School of Electrical Engineering, University of Pennsylvania, who developed ENIAC—the world's first electronic digital computer. All this plus a Computer Art and Graphics Display, a National Student Computer Fair, the annual Conference Reception, and many other high-interest events promise to make '76 NCC a landmark event for the entire computer industry.

Advance full-conference registration brings you the *NCC Bicentennial Card*, providing complete access to all four days of the Conference program, including exhibits. Benefits include a \$15 saving over the on-site full-conference registration fee, advance housing information and forms, and a copy of the '76 NCC Proceedings. Post-conference price of the Proceedings alone is \$50.

Fill in and mail the coupon below for advance registration or to get all the facts; or contact AFIPS, 210 Summit Avenue, Montvale, New Jersey 07645, telephone 201/391-9810.



'76 NCC, c/o AFIPS, 210 Summit Ave.,  
Montvale, N.J. 07645

- Yes, send me my *NCC Bicentennial Card*. I've enclosed the \$60 advance registration fee for the '76 NCC Conference Program and Exhibits plus special preregistration benefits.
- Please send me details about the Professional Development Seminars.
- Please continue to send me all the facts.
- My company is interested in exhibiting at '76 NCC.

Name \_\_\_\_\_  
Title \_\_\_\_\_  
Company \_\_\_\_\_  
Street \_\_\_\_\_  
City \_\_\_\_\_  
State \_\_\_\_\_ Zip \_\_\_\_\_

SID



## 1976 INTERNATIONAL SYMPOSIUM and EXHIBITION

THE BEVERLY HILTON HOTEL  
BEVERLY HILLS, CA / MAY 4-6, 1976

### GLOBAL INFORMATION DISPLAY ADVANCEMENTS IN DESIGN AND APPLICATIONS TO HIGHLIGHT SID '76

INTENSIVE ASSESSMENTS of worldwide information display design and application developments will be offered in over 60 papers at SID '76, to be held May 4-6 at the Beverly Hilton Hotel, Beverly Hills, California.

The reports, authored by more than 100 from here and abroad, will be presented during twelve daytime sessions. Featured, too, will be keynote, invited and luncheon talks on emerging trends in technology.

In the keynote address, to be presented during the opening-day session, Dr. James Hillier, RCA executive vice-president for research and engineering, will offer some thoughts on the future of information display, noting that the marketability of a display system is ultimately determined by the perceived value (relative to cost) of the information service provided by the total system. He will identify different classes of information service and analyze their broader implications for the development of new markets.

The keynote offering will be followed by a pair of invited discussions: one involving the cogent, and long overdue, need for exploring the quantum efficiency of the observer as a measure of the required quantum efficiency of the camera, and the other on the application of a new set of principles to permit decisions on the meaningful use of color as a visual display.

The initial appraisal will be offered by Dr. Albert Rose, a Fairchild Distinguished Scholar at the California Institute of Technology, who recently was also elected to the National Academy of Engineering. The second report will be delivered by Professor Warren Teichner of the Department of Psychology, New Mexico State University.

Invited talks, scheduled for the remainder of the program will cover computer output printing, graphanumeric displays—an emerging market, the advantages and limitations of contemporary color-TV picture tubes, a large-scale liquid crystal matrix display, and a voice recognition and synthesis system.

The broadening areas of interest in information display will also be under-scored during the meeting. Topics on the agenda include hard copy, liquid crystal displays, matrix displays and addressing techniques, interactive terminals, plasma device technology, display applications, display design criteria, electron beam devices—CRTs and flat panel, projection displays and image data compression.

Among the hard copy techniques to be reported will be a high speed serial inkjet printer, aerosol jet printing, micro-processor compatible thermal printhead and a high resolution thermal printer.

The role of the imaginative and adventuresome research and design engineer, often resulting in unique products, will be limelighted during a lively luncheon talk — Somewhere Under the Rainbow — by Henry Kloss of the Advent Corporation.

The traditional evening discussion sessions, where panelists and the audience can participate in spontaneous discussions, will again be held at the '76 Symposium. Three timely subject areas have been programmed: image evaluation factors, projection TV — the bright future, and potential for color in displays.

Another feature of the annual Sumposia — the Monday-Friday seminars — cosponsored by SID and a university, has also been scheduled this year. The University of California/Los Angeles and SID will offer eight in-depth tutorials by experts from universities and industry. Topic emphasis will be on image processing, in general, and on biomedical and message-transmission applications. Additional areas to be covered include pickup and display devices, charge-coupled imagers, CRTs and flat-panel displays for TV. Another aspect of TV to be explored includes color broadcasting and video disc systems, which should soon appear on the consumer market.

The ever-popular author interviews, affording face-to-face chats, with supporting operational prototype models, will again be held on two evenings of the meeting.

Also available at SID '76 will be the annual DIGEST of TECHNICAL PAPERS, with 800-1000 word illustrated condensations of all talks — invited and contributed — plus day-evening session overview editorials, and the seminar presentations. Additional copies will be available at the meeting and thereafter through the SID office in Los Angeles: \$15.00 for members and \$20.00 for nonmembers.

As in the past, an exhibition, reflecting the latest developments of operational systems, components and accessories, will be held during Tuesday, Wednesday and Thursday. On the first day, the show will open at 10:00 A.M. and close at 5:30 P.M. Following day hours will be 9:00 A.M. — 5:00 P.M. Closing day hours will be 9:00 A.M. — 3:00 P.M.

Advance registration fees for members are \$40.00; nonmembers, \$50.00. At-conference costs will be \$50.00 for members and \$60.00 for nonmembers. The seminar registration fee for one day is \$70.00 and \$110.00 for both the Monday and Friday sessions.

The SID '76 chairman is William E. Good, General Electric Co., Syracuse, NY; program chairman is John A. van Raalte, RCA Laboratories, Princeton, NJ.

Programs, to be published soon, will be available from the SID office, 654 North Sepulveda Boulevard, Los Angeles, CA 90049, or Lewis Winner, 162 W. 42nd St., New York, NY 10036.

William E. Good, Chairman  
General Electric Company

#### TUESDAY/MAY 4

KEYNOTE: The Future of Information Displays  
J. Hillier, RCA Corp., New York, NY

#### INVITED/Vision - - Human and Electronic

A. Rose, California Institute of Technology, Pasadena, CA

#### INVITED/Design Principles for the use of Color in Displays

W.H. Teichner, New Mexico State University, Las Cruces, NM

#### INVITED/Computer Output Printing

R.A. Myers, IBM T.J. Watson Research Ctr., Yorktown Heights, NY

#### Potential Speed and Resolution Capabilities for Ink Jet Printing

J.J. Stone, Jr., A.B. Dick Co., Elk Grove Village, IL

DAY SESSIONS

- High Speed Serial Ink Jet Printer**  
Y. Sumitomo, T. Kobayashi, Y. Yamakoto, M. Aiba, S. Kinpara and S. Mito, Sharp Corp., Nora, Japan
- Aerosol Jet Printing**  
W.B. Pennebaker, IBM T.J. Watson Research Ctr., Yorktown Heights, NY
- Controlled-Ion-Flow Electrostatic Printing**  
G. Pressman, Electroprint, Inc., Cupertino, CA
- Microprocessor Compatible Thermal Printhead**  
W.S. Henrion, Texas Instruments, Inc., Houston TX
- High Resolution Thermal Printer**  
S. Nakaya and A. Watanabe, Oki Electric Industry Co., Inc., Tokyo, Japan
- INVITED/Large-Scale Liquid Crystal Matrix Display**  
K. Ono, E. Mitani, E. Kaneko and M. Sato, Hitachi Ltd., Tokyo, Japan  
S. Fujii, Dai Nippon Toryo Co., Ltd., Chigasaki-shi, Japan  
S. Furuuchi, Asahi Glass Co., Ltd., Tokyo, Japan
- Twisted Nematic Displays for Multiplexing**  
A.R. Kmetz, T.J. Scheffer, J. Nehring and W. Hollinger  
Brown Boveri Research Ctr., Baden, Switzerland
- Triode Optical-Gate Liquid Crystal Devices for Dynamic Image Displays**  
D.J. Channin, RCA Laboratories, Princeton, NJ
- A Non Scanning Matrix Addressing Technique for Certain Liquid Crystal Displays**  
W.L. Carl, Integrated Display Systems, Inc., Montgomeryville, PA  
C.R. Stein, General Electric Co., Schenectady, NY
- A Liquid Crystal Bar Graph Meter**  
S. Sherr, North Hills Electronics, Inc., Glen Cover, NY
- A Multichip MOS Video Liquid Crystal Display**  
C.P. Stephens and L.T. Lipton, Hughes Aircraft Co., Carlsbad, CA
- Human Factors Design Criteria for Liquid Crystal Displays**  
W.L. Martin, Aerospace Medical Research Laboratory, Wright Patterson AFB, OH

## WEDNESDAY/MAY 5

- Character Display using Thin-Film EL Panel with Inherent Memory**  
C. Susuki, Y. Kanatani, M. Ise, E. Misukami, K. Inasaki and S. Mito  
Sharp Corp., Nara, Japan
- Limitations on the Size of Monolithic X-Y Addressable LED Arrays**  
B.L. Frescura, Hewlett-Packard Laboratories, Palo Alto, CA
- Some Recent Advances on the Development of the Magnetic Particles Display**  
L.L. Lee, The Magnavox Co., Fort Wayne, IN
- Bipolar Integrated Circuit Plasma Panel Drive System**  
J.W.V. Miller and J.D. Schermerhorn, Owens-Illinois, Inc., Toledo, OH
- A Display/Memory Unit with Light Pen Capability**  
A.C. Cribbs, Owens-Illinois, Inc., Toledo, OH  
P.D.T. Ngo, Bell Laboratories, Holmdel, NJ
- INVITED/The VRAS System**  
R.J. Wherry, Jr., Naval Air Development Ctr., Warminster, PA
- Design and Evaluation of a Text Editing Console**  
T. Bentley, Tektronix, Inc., Beaverton, OR
- A Display Processor for High Efficiency Text Editing**  
R.B. Kalin, Digital Equipment Corp., Maynard, MA
- A Microprocessor-Based Visual Communications Terminal**  
T.F. Sesnowski and R.C. Brainard, Bell Laboratories, Holmdel, NJ
- Microprocessor-Based Display Terminal**  
D.J. Heller and B.H. Fagan, General Electric Co., Pittsfield, MA
- A Monolithic Constant-Velocity Vector Generator**  
M.L. Rieger, Tektronix, Inc., Beaverton, OR
- A Green AC Plasma Display**  
H. Yamashita, S. Andoh and T. Shinoda, Fijitsu Laboratories, Ltd., Hyogo, Japan
- Theory of Memory Effects for the AC Plasma Display Panel**  
L.F. Weber, University of Illinois, Urbana, IL
- State Flipping of a Plasma Panel Cell**  
P.D.T. Ngo, Bell Laboratories, Holmdel, NJ
- Coupled-Matrix, Threshold-Logic AC Plasma Display Panel**  
T.N. Criscimagna, J.R. Reidl, M. Steinmetz and J. Hevesi  
IBM Corp., Kingston, NY

## TUESDAY/MAY 4

- Image Evaluation Factors**  
**Projection Television — The Future is Bright**

- Solid-State Image Transducers**  
David F. Barbe, Naval Res. Lab., Washington, DC
- Approaches to Flat-Plan TV Displays**  
Alan Sabel, Zenith Radio Corp., Chicago, IL

- Digital Image Enhancement and Restoration Display Techniques**  
William K. Pratt, Univ. of So. California, Los Angeles, CA
- Biomedical Image Processing**  
Jack Sklansky, Univ. of California, Irvine, CA

- Tubular Transparent Plasma Graphics Panel**  
J.O. Atkins, Control Data Corp., Minneapolis, MN
- Analysis and Performance of Hg-Buffer Gas Display Panel Discharge Cells**  
M. McDonough and A.B. Budinger, GTE Laboratories, Waltham, MA
- INVITED/Graphnumeric Displays — an Emerging Market**  
G. Wasserman, Arthur D. Little, Inc., Cambridge, MA
- Accessing and Displaying High Resolution Micro-image Information**  
R.A. Botticelli, D.J. Walker and G.N. Wallmark,  
Epsco Laboratories, Wilton, CT
- An Interactive Ocean Traffic Geographic Display System**  
S.E. Arkin and B.E. Martin, Jr., Naval Research Laboratory,  
Washington, DC
- Human Factors Aspects of Display Design**  
R.I. Rosenthal, Bell Laboratories, Holmdel, NJ
- An Associative Approach to Display Processing**  
J.M. Vocar and W.C. Meilander  
Goodyear Aerospace Corp., Akron, OH
- A Three-Dimensional Display with True Depth and Parallax**  
G.L. Lazik, Perceptronics, Inc., Woodland Hills, CA

## THURSDAY/MAY 6

- INVITED/Dot-Matrix Alphanumeric Identification as a Function of Font and Discrete Element Degradation**  
T.M. Riley, Bunker-Ramo Corp., Dayton, OH
- Relative Effectiveness of Color Coding**  
R.E. Christ, New Mexico State University, Las Cruces, NM
- Target Acquisition Performance with Color Versus Black and White TV**  
D.W. Wagner, Naval Weapons Center, China Lake, CA
- A Comparative Study of Active and Passive Displays for Cockpit Use**  
J.H. Wharf, D.V. Peters, R.N. Tyte and B. Ellis,  
Royal Aircraft Establishment, Hants, England
- Prediction of Modulation Detectability Thresholds for Line-Scan Displays**  
R.L. Keesee and H.L. Snyder, Virginia Polytechnic Institute and State University, Blacksburg, VA
- Computer Input using Reduced Keystets**  
E.H. Hilborn, U.S. Dept. of Transportation, Cambridge, MA
- INVITED/Twenty-Five Years Without Panel TV**  
J.W. Schwartz, Zenith Radio Corp., Niles, IL
- The Shaped Beam Tube for Computer Displays**  
D.J. Haflinger, Stromberg Datagraphix, Inc., San Diego, CA
- A Monolithic IC for Pincushion Distortion and De-Focus Correction**  
H.L. Golladay and B.A. Rosarie, Tektronix, Inc., Beaverton, OR
- Flat Panel Multi-Digit Fluorescent Display**  
K. Kiyozumi, M. Masuda and T. Nakamura  
Ise Electronics Co., Ise-Shi, Mie Pref., Japan
- A Hybrid Flat Display System**  
M.D. Sirkis, H.I. Refioglu, I. Kaufman and G.E. Huling,  
Arizona State University, Tempe, AZ
- A Flat Panel TV Display**  
R. Schulman and J.W. Schwartz, Zenith Radio Corp., Niles, IL
- A High Performance Large Screen CRT Projector**  
R.A. Wileman and R.E. Thoman, General Dynamics Corp., San Diego, CA
- A Bistable Electret Display Device**  
J.L. Bruneel, J.J. Crosnier, J.P. Huignard and F. Micheron  
Thomson, CSF, Orsay, France
- A Low Noise Image Amplifier**  
J.M. Pollack and J.B. Flannery, Xerox Corp., Rochester, NY
- Improved Liquid Crystal Image Storage Device**  
J. Adams, G. Dir, I. Gates, W. Haas, K. Nelson, J. Stephany and S. Tutihasi, Xerox Corp., Rochester, NY
- Data Reduction of Dither Coded Images by Bit Interleaving**  
C.N. Judice, Bell Laboratories, Holmdel, NJ
- Compressing Ordered Dither Images with 2-D Pattern Matching**  
R.L. Johnson and A.B. White, University of Illinois, Urbana, IL
- Efficient Frame Memory Storage of a Color TV Picture**  
R.D. Solomon, MIT, Cambridge, MA

## WEDNESDAY/MAY 5

- Potential for Color in Displays**

## MONDAY/MAY 3

- US Color TV Fundamentals — A Review**  
Dalton H. Pritchard, RCA Laboratories, Princeton, NJ
- A Review of Video Disc Systems**  
Jon K. Clemen, RCA Laboratories, Princeton, NJ  
John Winslow, MCA-Discovision, Torrance, CA

## FRIDAY/MAY 7

- Analog and Digital Techniques for High-Speed Facsimile**  
Bruno J. Vieri and John D. Torpie, Xerox Corp., Dallas, TX
- Fundamentals of CRTs: A Tutorial Review**  
Peter Seats, Thomas Electronics, Inc., Wayne, NJ

SID

## NEW PRODUCTS

## MULTI-CORE FIBER OPTIC COMMUNICATIONS CABLE

A new multi-core fiber optic communications cable is available in various numbers of optical and electrical channels and configurations.

Pictured is a cable containing sixteen fiber optic channels plus three conventional wire links, a product developed for linking a computer main frame to peripheral equipment operating in a noisy electrical environment.



Designated "Fibroflex 400X," this new product is based on a prior multi-core fiber optic communications cable that contains 96 fibers jacketed in PVC and which withstands a continuous operating temperature of 105° C. (221° F.) with an attenuation of less than 400 dB/km at 800 n.m. The fiber optic channels and wirelinks are color coded and grouped in conventional electrical cable arrangement. Jacketed in PVC to form a compact and flexible link, "Fibroflex 400X" has a lower operating and storage temperature of -40° C. and F.

Rank Precision Industries, Inc.  
411 East Jarvis Avenue  
Des Plaines, Ill. 60018

Circle Readers Service No. 100

## INTEGRATED PHOTOMULTIPLIERS

DuMont announces the DH2000 Series of low-cost integrated photomultiplier devices. The units are designed for OEM applications in laser scanning and light measurement systems. Other applications are in sensing, measurement, and control systems and devices for industrial and laboratory use.

DH2000 Series units accept standard head-on photomultiplier tubes up to 2 inches in diameter. The housing acts as a light-tight enclosure and provides electromagnetic and electrostatic shielding. Three models are available, the

DH2050 — with integrated, voltage-programmable power supply, the DH2025 — with integrated, manually-adjustable power supply, and the DH2010 — with potted interdynode resistor network, for use where external phototube power is available.



End caps for aperture and filter mounting may be supplied by the user or can be ordered from DuMont.

DuMont Electron Tubes and Devices Corporation  
750 Bloomfield Avenue  
Clifton, NJ 07015

Circle Readers Service No. 101

## HIGH POWER LASER

LEXEL has extended its line of higher power lasers with the new Model 96, an argon laser that delivers up to 5W of TEM<sub>00</sub> power and 6W of MTM power.

The Model 96 laser is intended for applications in spectroscopy, dye pumping, holography, laser doppler velocimetry, medicine and biochemistry, and photocoagulator systems.



This argon laser incorporates design features as in earlier LEXEL models to yield the same reliability and stability. It features a permanently sealed gas reservoir, thus eliminating the problems of gas fill systems; a solid invar rod resonator structure for mechanical integrity and exceptional stability; and a continuously active getter that assures easy starting after indefinite shelf life.

By complying with the BRH Performance Standards for Class IV lasers, it incorporates key control, radiation emission indicators, beam attenuator, safety interlock, remote control connector, and all required labeling.

LEXEL Corporation  
928 East Meadow Drive  
Palo Alto, Ca.

Circle Readers Service Card No. 102

## SELF-CONTAINED IR AMPLIFIER — POWER SUPPLY

The model AXRP-309 series amplifier-power supply is a complete IR transmitter, receiver and power supply modular system component for use with a wide variety of STI sensor heads.

The self-contained unit is packaged in a rugged anodized aluminum enclosure, approximately 4" x 1 3/4" x 1 1/2" (10.3 cm x 4.4 cm x 3.8 cm) which is a totally epoxy encapsulated, water tight, shock proof module.

The new unit incorporates STI pa-  
Information Display / Page 27

tented solid state circuitry which permits highly sensitive optical detection with complete avoidance of ambient light interference from external sources, including bright sunlight, atmospheric contaminants, dust, oil vapors and films, and airborne condensations such as fog or rain. Input power is standard 12 VAC, 12 VDC and 24 VDC. A standard 10 VDC logic signal capable of sourcing 1 milliamp and sinking 100 milliamps is provided. This output is capable of driving a 12V coil on mechanical relays and can be pulled up to 12-30 VDC through the use of an external pull-up resistor. The regulated power supply has automatic short circuit protection. The unit can be used with batteries due to its low power requirement.

and decay times of 50 nsec can be measured, and total radiant energy in pulses as short as 180 nsec can be accurately integrated.

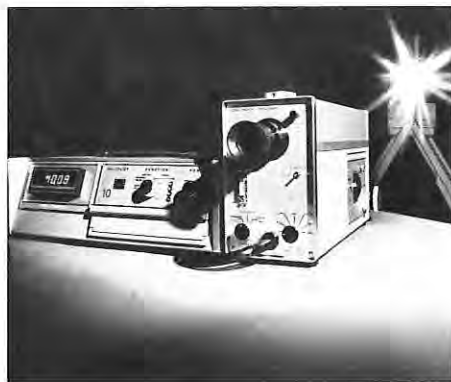

The 1980A-PL features electronic autoranging over 4 full ranges, providing 6 decades of direct readout without operator adjustments over a full-scale sensitivity range of from  $10^{-5}$  to  $10^7$  foot-Lamberts. A built-in AutoComp™ system automatically compensates for any changes in filter, electronic gain, or aperture settings. The result is direct reading with no correction factors. The AutoZero™ system automatically zeros out steady-state ambient light and dark current.

Photo Research  
Division of Kollmorgen Corporation  
3000 North Hollywood Way  
Burbank, Ca. 91505

Circle Readers Service Card No. 104

#### LARGE-SIZE READOUTS

An expanded line of Signalex<sup>R</sup> electromagnetic numeric readouts has been announced by The Staver Company. Added to the original 1½" H Signalex 150L, the new displays will be available in sizes up to 12" H. All are electromagnetic 7-segment readouts for pulse operation, providing the advantages of inherent memory and high visibility in ambient light.

The 4" Signalex 400L and 6" 600L are easily legible at distances up to 100 ft. and 200 ft., respectively. The 400L requires a minimum pulse width of 50 milliseconds and just under 1 watt per segment during pulse. The larger 600L requires a pulse width of at least 90 milliseconds and less than 1¼ watts per segment.

The circuits are balanced, in duration and current level, for equal display and retract pulses. Windings, which are

standard for 12 VDC operation, can be specially designed for individual production applications. Both units may be used in ambient temperatures from -40° to +180° F. In ambient temperatures not exceeding 150°F, continuous current may be applied.

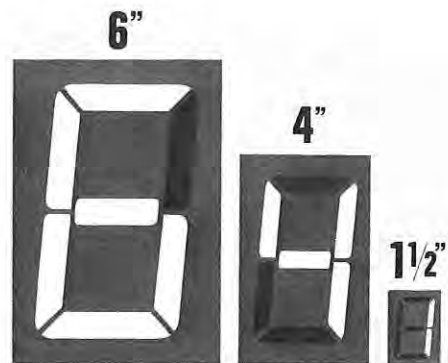

Extra-large-size Signalex displays, 9" and 12", for truck weighing scales, scoreboards, outdoor signs and similar applications are available in prototype quantities. With electromagnetic actuation and pulse operation, they will be significantly under the power requirements of the usual large-size devices. All Signalex readouts have inherent memory, with current needed only to change displays, never to maintain them. Standard colors are white on black, with customized colors available on special order.

Staver Company, Inc.  
41-51 N. Saxon Avenue  
Bay Shore, N.Y. 11706

Circle Readers Service No. 105

#### LED LAMP DIRECTLY INTERCHANGEABLE WITH INCANDESCENT

Developed as a direct replacement for the T-1 ¾ incandescent equivalent, Dialight's new series 549 Bi-Pin lamp is a Gallium Arsenide Phosphide device with red diffused lens and is offered in 2 models.

One has an integral resistor for direct use at 5V, 16 mA, and the other, a 1.7V unit, requires an external series resistor.

Company design makes dense packaging possible on printed-circuit boards. Pins are molded in a black plastic case, which has a flat for indexing to establish correct polarity. Terminations are 0.025" square leads with gold plating, which is an aid in soldering. Rigidity of the leads provides for easy insertion and removal from sockets, or for direct printed-circuit board mounting.

These units offer high reliability with life measured in years, and are immune to shock and vibration and can be driven directly from DTL and TTL logic.

The Bi-Pin lamp with a built-in resistor is offered at prices competitive with other LED lamps sold without a resistor.



In 1,000 lot quantities, each unit sells for \$.54 each w/o resistor, and \$.69 each with resistor. Availability is from stock.

Dialight  
203 Harrison Place  
Brooklyn, NY 11237

Circle Readers Service No. 106

#### 14 DIGIT PLANAR DISPLAY

A new gas discharge display with .25" high neon orange characters has just been introduced by Cherry Electrical Products of Waukegan, Illinois. Compact in size, the unit measures 4.4" x .905" x .197".

Called Plasma-Lux, the 7 segment, 14 digit display is Part No. W14-0003. In addition to the 14 numerals, the unit has decimal points and commas and can be shipped separately or with a special unitized connector (W30-1430) that has bifurcated contact tabs for positive, reliable connection.



The W14-0003 gas discharge display is neon orange in color for ease of visibility and is readily filtered. This bright digital readout is ideal for such applications as electronic calculators, instruments and other electronic equipment. List price on the W14-0003 Plasma-

Lux display is \$16.89 with net cost of \$6.59 in 2,000 piece quantity. The W30-1403 unitized connector has List price of \$2.61 with net cost of \$1.02 at the 2,000 piece quantity level.

Cherry Electrical Products Corp.  
3600 Sunset Avenue  
Waukegan, Ill. 60085

Circle Readers Service No. 107

#### ACHROMAT LENSES

Melles Griot (formerly Optical Industries) has introduced an extensive line of computer optimized achromat lenses with focal lengths ranging from 10mm to 1185mm.

Available in diameters from 6mm to 80mm, these achromats have been designed with infinite conjugate ratios for widest use. Coma, astigmatism and inward field curvature have been suppressed over a 5 degree angular field, covering the majority of instrumental applications.



Optimum f-number occurs at nearly full aperture for each lens.

Prices of the computer optimized achromats range from \$21.50 to \$118. Lenses are shipped from stock with anti-reflection coating for the visible range. Laser line "V" coatings and HEBBAR™ coatings are also available.

Melles Griot  
3006 Enterprise Street  
Costa Mesa, Ca. 92626

Circle Readers Service No. 108

# CATHODE RAY TUBES

WE OFFER YOU TECHNICAL ABILITY FOR ANY SPECIAL CRT AND DISPLAY SYSTEM

**CRT**  
FIBER OPTIC FACE  
BACK PORTED  
MONOSCOPES  
HIGH RESOLUTION  
CUSTOM GEOMETRIES  
PHOSPHOR SCREENS  
ELECTRON OPTICS.



**SYSTEMS**  
FLYING SPOT SCANNERS,  
MONITORS, FIBER OPTIC  
PRINTERS, DATA TERMINALS.

DESIGN — DEVELOPMENT —  
PRODUCTION — TUBES AND  
SYSTEMS.

M. SADOWSKY

S. CARLISLE

P. KEEGAN

## SPECIAL PURPOSE TECHNOLOGY CO.

16300 LINDBERGH STREET, VAN NUYS, CALIFORNIA 91406  
TELEPHONE: (213) 989-4610



The AXRP-309 can be converted to any of STI's standard solid-state IR sensor heads for configuration in the reflex, transmitter beam or proximity modes. Optional cable lengths can be fitted; up to 150 feet (46 meters) at the sensor end and 500 feet (150 meters) at the output.

Delivery of the basic Model AXRP-309 is two weeks and single unit price is \$78.00. Quantity discounts and special configurations to OEM specifications are also available.

Scientific Technology Incorporated  
1201 San Antonio Road  
Mountain View, Ca. 94043

Circle Readers Service Card No. 103

#### AUTOMATIC PULSED-LIGHT PHOTOMETER

Photo Research has introduced a fully automatic pulsed-light photometer, the Spectra® Pritchard® 1980A-PL. The unit includes a wide-band output signal jack for measuring pulse shapes and peak power with the aid of an oscilloscope. It also offers direct digital readout of integrated radiant energy in a single pulse or a series of pulses. Minimum pulse rise

## SUSTAINING MEMBERS

**AERONUTRONIC FORD CORP.**  
WDL Division, Palo Alto, California

**AYDIN CONTROLS**  
414 Commerce Drive, Fort Washington 19034

**BURROUGHS CORPORATION**  
Federal and Special Systems Group,  
Electronic Components Division,  
Plainfield, New Jersey 07061

**CARDION ELECTRONICS**  
A Division of General Signal Corporation  
Long Island Expressway, Woodbury, NY 11797

**CHERRY ELECTRICAL PRODUCTS CORP.**  
3600 Sunset Ave., Waukegan, Illinois 60085

**CONRAC CORPORATION**  
330 Madison Ave., New York, New York 11017

**DATA DISC, INCORPORATED**  
686 West Maude Avenue, Sunnyvale, CA 94086

**DISPLAY COMPONENTS, INC.**  
550 Newtown Rd., Littleton, Mass. 02460

**DuMONT ELECTRON TUBES  
AND DEVICES CORP.**

750 Bloomfield Ave., Clifton, NJ 07015  
**FERRANTI ELECTRONIC COMPANY**  
Plainview, New York

**GENISCO COMPUTERS**  
17805 Skypark Circle Dr., Suite D,  
Irvine, California 92707

**GML INFORMATION SERVICES**  
594 Marrett Road, Lexington, Mass. 02173

**HEWLETT-PACKARD COMPANY**  
1900 Garden of the Gods Road,  
Colorado Springs, Colorado 80907

**HUGHES AIRCRAFT COMPANY**  
Culver City, California 90230

**IBM CORPORATION**  
Armonk, New York

**NAC INCORPORATED**  
17 Kowa Bldg., No. 2-7, Nishiazabu 1-chrome  
Minato-ku, Tokyo, Japan

**OPTICAL ELECTRONICS, INC.**  
P.O. Box 11140, Tucson, Arizona 85734

**OWENS ILLINOIS, INC.**  
P.O. Box 1035, Toledo, Ohio 43666

**PHOTO RESEARCH DIVISION**  
Kollmorgen Corporation  
3000 N. Hollywood Way, Burbank, CA 91505

**RANK ELECTRONIC TUBES**  
**RANK PRECISION INDUSTRIES LIMITED**  
Sidcup By-Pass, Sidcup, Kent, England

**RAYTHEON COMPANY**  
Industrial Components Operation  
465 Centre Street, Quincy, Mass. 02169

**REDACTRON CORPORATION, INC.**  
OEM Division, 100 Parkway Drive South  
Hauppauge, New York 11787

**SIEMENS AG**  
Components Marketing, 76 St. Martinstr.,  
Munich, West Germany

**SINGER-LIBRASCOPE**  
Aerospace & Marine Systems Group  
833 Sonora Avenue, Glendale, California 91201

**SYNTRONIC INSTRUMENTS, INC.**  
100 Industrial Road, Addison, Illinois

**TEKTRONIX, INC.**  
Information Display Products  
P.O. Box 500, Beaverton, Oregon 97005

**THOMAS ELECTRONICS, INC.**  
100 Riverview Drive, Wayne, New Jersey 07470

**THOMSON-CSF**  
Paris, France

**XEROX CORPORATION**  
El Segundo, California 90245

## ADVERTISERS INDEX

Constantine Engineering Labs., Co. (Celco) . . . . .	31
Dumont (Thomson-CSF) . . . . .	32
General Electric . . . . .	30
Melles Griot . . . . .	18
Metavac Inc. . . . .	21
National Computer Conference . . . . .	24

RCA Display Devices . . . . .	9
Special Purpose Technology Company . . . . .	29
Spellman High Voltage Electronics Corp. . . . .	19
Syntronic Instruments, Inc. . . . .	2
Thomas Electronics, Inc. . . . .	5
Washburn Lab., Inc. . . . .	18
Watkins Johnson . . . . .	17

# Picture your board room with bright, color video graphics



The ever growing use of data processing is providing an important planning and analysis resource for executives in a broad spectrum of business: from bankers, to bakers, to candlestick makers.

The computer's expanding involvement with daily operations produces a wealth of information that often requires frequent presentation to groups of six, sixty, or six hundred or more people.

### Illustrate your data bank

The most valued and versatile component in your information system could be the large screen color television projector . . . the incomparable General Electric PJ5000. Coupled to your computer facilities through suitable interface equipment, it can project Alpha-numeric data, graphic displays and computer generated images, in real time, for instant review and analysis. In addition, it can project information from all standard video sources.

Just visualize a 2 to 20 foot wide TV screen with fast breaking investment data, or sales information for immediate discussion and decision, being presented in color. Or corporate strategy ideas being immediately fed to the computer and their likely consequences projected as "war game" conclusions in TV graphs and charts.

All the advantages of utilizing computer data bank information as a decision making resource are greatly magnified by the use of large screen TV projection. The GE PJ5000 is designed to deliver a dependable professional performance with ease of operation. The GE exclusive single gun, single optical path system projects bright, natural color pictures with inherent color registration, on large screens for front or rear projection.

The PJ5000 is easily transportable and ready to move from your board room, to any other location, and it operates from standard 120v/20 amp appliance outlets. Its compact, self-contained Control unit can be removed from the projector, for remote set-up and operating control, with the addition of an accessory control cable.

The PJ5000 solid-state, high brightness, color video projector is engineered for excellent picture quality and power efficiency, with ease of operation, maintenance and service.

To find out more on how to present your data in a dynamic new light, call (315) 456-2562 or 456-2533 today, or write to:

Video Display Equipment Operation  
General Electric Company  
Electronics Park, 6-206  
Syracuse, New York 13201

**The GE large screen color TV projector... PJ5000**  
**GENERAL ELECTRIC**



# CELCO's Computer- controlled Step & Repeat Camera can reproduce your High- Resolution photographic computer imagery to 4096 lines.

CELCO's Computer-Controlled Step & Repeat Camera can reproduce your digitized photographic data on plate or film to 4096 lines.

The CELCO SRC produces typographic font masters for the printing industry, clothing patterns for garment manufacturers, or hybrid circuit and micro-circuit mask fabrication. CELCO's Camera is designed for precision registration of highly accurate, computer-accessed photographic data.

### The System features:

- X-Y step and repeat table for up to 10" x 10" travel. Other configurations are available.
- Automatic multi-lens selection
- 0.05% non-linearity
- 0.01% Long Term Stability and Repeatability

### CAMERA ELECTRO-OPTICAL SYSTEM SPECIFICATIONS:

CRT Resolution	0.001" line width standard.
LENSES	Computer-selectable lens turret available if required. Accommodates 4 lens positions.
IMAGE PROPERTIES:	
Linearity	0.05% ±1 LSB or better.
Long Term Stability and Repeatability	Better than 0.01% ±1 LSB.
Limiting Resolution	100 line pairs/mm aerial with 50 line pairs/mm limiting resolution guaranteed on Kodak CPN4301 Ortho III photographic plates.
SKEW & PARALLELISM	0.025% ±1 LSB
OPTIONAL EQUIPMENT:	
X-Y Step and Repeat Tables	For up to 10" x 10" travel. Other configurations available.
Automatic Lens Selection	For up to 4 on-line stations.

CONSTANTINE ENGINEERING LABORATORIES COMPANY  
1150 E. Eighth Street, Upland, CA 91786

70 Constantine Drive, Mahwah, N.J. 07430

